

P&H[®] Century T-500

**Hydraulic Truck Crane
50 Ton Maximum Capacity
170 ft. (51.8 m) Boom plus Extension**



- Travels over 50 mph highway speed.
- Roadable in most states.
- Four-plate boom, welded inside and out gives superior strength. No derate for bucket work.
- Two swingaway lattice extensions are available: a one piece, 35' extension and a telescopic 35' to 60' extension. The 35' extension has a removable point section for easy conversion to telescopic type. Both can be offset to 17° or 30° for up and over reaches.
- Extra rugged construction for long life on the tough jobs.
- P&H winches have 'bent axial' piston motors, strong line pulls, fast line speeds.
- Operator's cab is roomy, vibration isolated, with deluxe seat for comfort, handy controls for easy operation.

Specifications

Specifications

ITEM NO.

This P&H crane meets the requirements of ANSI B30.15 (1982). Boom structure (boom, lattice extension and jib) has been tested per SAE J1063, machine stability tested per SAE J765. LOAD RATINGS shown apply only to machine as manufactured and marketed by Century II, Inc.

1

BASIC MACHINE

Attachment



Boom: 34 ft. (10.4 m) retracted to 110 ft. (33.5 m) extended length, four section boom consisting of a boom base, two hydraulically extended and retracted sections and a fourth pinned section which can be hydraulically extended and retracted. Boom point has five 17.362" (440mm) dia. main metallic sheaves with roller bearings and two idler sheaves with bronze bearings.

Each section of this rectangular boom consists of four plates welded both inside and out for superior strength. Large, non-metallic slider pads are adjustable.

For performance characteristics, see Chart no. 1, Crane Range Diagram, and Charts nos. 2, 3, 8 and 9, Lifting Capacities on Main Boom.

See Optional Equipment for lattice extensions, auxiliary sheave, and hook blocks.

Counterweight: 8,000 lbs (3630 kg) standard, non-removable type. 1080 lbs. (490 kg) auxiliary counterweight to be used on units without an auxiliary winch.

Upperstructure



Operator's Cab: Fully enclosed, all-weather steel cab with full vision safety glass and hinged top window with tinted glass. Cab is cushion-mounted for vibration isolation.

Operator's Cab Standard Equipment: Contains all crane function controls. Front control console includes: engine water temperature gauge, engine oil temperature gauge, hydraulic oil temperature gauge, air pressure gauge, fuel gauge, volt meter, winch high speed indicators; main winch drum turn indicator, dash light, electrical horn, windshield wiper, tachometer. Deluxe operator's seat with torsion suspension and vinyl covering, fire extinguisher and seat belts.



Controls: Joy-stick controls are an integral part of the seat arm rests. Left hand side operates swing and auxiliary winch. Right hand side operates main winch and boom hoist. Front floor mounted foot pedals for swing brake, boom telescope and engine throttle. Front console instrument panel contains ignition switch, hand throttle control, swing lock control, electrical outrigger control panel tachometer, oil pressure, voltage, water temperature and fuel level gauges.

Electrical system: 24 volt negative ground. Wiring harnesses have protective covering and are independently clamped to the framework, and have environmentally sealed Deutsch connectors. Toggle switches in operator's cab are environmentally sealed.

Throttle Control: Variable electrical control for foot operation, and positive position cable control for hand use.

Operational Aids

Krueger (ATB) anti-two block warning device with audio-visual warning. For main boom only.

Krueger (HAP) boom angle indicator with audio-visual warning.

Winches



Main Winch: P&H model 1580 with two speed, bent axial piston motor, mounted to rear of revolving frame. Planetary gearing and equal speed, power raising and lowering. Infinitely variable speed control. Spring applied, hydraulically released load holding multi-disc brake is automatic. Complete with 550' of .75" wire rope.

Drum: 15" (381mm) pitch diameter
18.5" (479mm) wide
23.5" (597mm) flange diameter

Wire Rope: .75" (19mm) dia. 6 x 25 extra improved plow steel with 7x7 IWRC. Strength limit: 16,800 lbs. (7,619 kg).

Drum Capacity: 554 ft. x .75" (19mm) dia., 5 layers.

Line Pull (max.): 18,282 lbs. (8,291 kg) 1st layer, low speed.
13,223 lbs. (5,997 kg) 5th layer.

Available Line Pull (for starting loads in mid-air) (max.): 11,000 lbs. (4991 kg) 5th layer

Line Speed (max.): (At 2750 engine rpm and with .75" wire rope)
642 ft./min. (196 m/min.) 5th layer, high speed.

See Chart No. 5, Hoist Reeving, for rope capacities and parts of line required.

Auxiliary Winch: See Optional Equipment.

SHEAVE AND DRUM TO WIRE ROPE RATIOS: (Pitch Diameters)	Sheave to Wire Rope	Drum to Wire Rope
Main Boom Sheaves .75" Wire Rope .625" Wire Rope	24.15:1 28.78:1	- -
Main Winch .75" Wire Rope .625" Wire Rope	- -	20.0:1 23.8:1

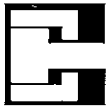

Boom Hoist: Two 7.874" (200mm) I.D. cylinders, double-acting. Hydraulically powered raising and lowering with holding valve.

Boom Telescope: Two 6.3" (160mm) I.D. cylinders, double-acting. Hydraulically powered raising and lowering with holding valve. Supplied by a single hose loop.

Hydraulic System

Filters: Two 10-micron nominal return line filters mounted externally of the hydraulic reservoir. All return oil is filtered. Indicators external.

Pump Drive: Driven off carrier engine crankshaft, with manual pump disconnect for highway travel. 1.260 pump speed to 1.0 engine speed drive ratio.

Pumps: One tandem gear pump operating at 2646 full load rpm, with the first section providing 51.7 gpm (196 l/m) to the boom hoist and telescope circuits, and the second section providing 42.5 gpm (161 l/m) to the main and auxiliary winch circuit.

One tandem gear pump operating at 2646 full load rpm, with the first section providing 27.4 gpm (104 l/m) to the outrigger and winch boost circuits, and the second section providing 35.1 gpm (133 l/m) to the swing circuit.

One Vickers vane pump, driven from the engine accessory drive, operating at 2100 full load rpm, provides 19.5 gpm (74 l/m), regulated to 8 gpm (30 l/m) to the steering circuit.

Oil Reservoir: 172 gallons (651 liters) mounted at front, right side of engine frame.

Oil Cooler: Oil to air, tube and fin type with internal turbulator.

Control Valves: One single spool valve for swing circuit.

One two spool valve with one spool for boom hoist and one spool for telescope circuits.

One two spool valve, with one spool for main winch and one spool for auxiliary winch circuits.

Control lever shut-off device for anti-two block, boom angle indicator and load moment systems.

Swing System



Swing Unit: Hydraulic motor driving through gear reducer to pinion gear. 360° continuous rotation to 2.4 rpm full load.

Swing Gear: Single shear ball swing bearing with internal spur gear.

Swing Brake: Spring applied, hydraulically released, internal disc brake, integral with swing reducer. Hand brake control lever mounted on side console in cab. A manual foot pedal applies brake for static holding.

House Lock: 360° gear segment type lock manually engaged with house lock lever in cab.

Carrier



Type: P&H 8 x 4

Weight: Including ball bearing swing circle, hydraulic outriggers, and standard tires: 34,099 lbs. (15,447 kg).

Frame: Rectangular frame members of 80,000 psi (5600kg/cm²) yield strength alloy steel, reinforced with box constructed cross members of 80,000 psi (5600kg/cm²) yield strength alloy steel. Engine frame is channel construction of 47,000 psi (3300 kg/cm²) yield strength alloy steel.



Outriggers: Hydraulic out and down type. Eight double-acting hydraulic cylinders for independent horizontal and vertical motion of each beam operated from the operator's cab or at each side of the carrier. Each vertical cylinder is equipped with a holding valve.

Outrigger beams: 100,000 psi yield strength alloy steel box extending to a maximum spread of 23' 7" (7.2 m) from centerline of float to centerline of float with the machine fully raised on the outriggers. Retracted width of the outriggers without floats is 9' 10" (3.0 m).

Outrigger Floats: Individually removable floats with storage on carrier. Float size 24" (610mm) dia. with effective nominal surface area of 452 sq. in. (2920 cm²) per float.

Steering: Hydraulic powered gear and integral valve with a hydraulic power assist cylinder on each front axle. Tilt and telescope steering column standard.



Cab: One man, left side, low profile fully enclosed all-weather steel cab with full vision safety glass. Cab is cushion mounted for vibration isolation.

Cab Equipment: Contains all controls and instrumentation, including illuminated instrument panel with speedometer, tachometer, hour meter, voltmeter, air pressure gauges, low air pressure indicator lights, fuel gauge, oil pressure gauge, water temperature gauge, air horns, west coast mirrors, electric windshield wiper, windshield washer, engine conditioning warning system with noise alarm and warning light for high temperature and low oil pressure, heater and defroster, Deluxe operator's seat with torsion suspension and vinyl covering, seat belts.

Lights: Dual headlights, taillights, stop lights, front and rear direction signals with emergency flashers, rear license plate light, front, rear and side clearance lights with reflectors, dome light, and front and rear identification lights.

Miscellaneous Carrier Equipment: Front bumper, full fenders, sliding engine hood, tow hooks front and rear, carrier mounted boom rack, dunnage boxes, float storage racks, audio back-up warning device, fire extinguisher.

Brakes, Service: Front axles - air operated, cam actuated drum and shoe type.

Rear axles - air operated, spring type safety chambers, cam actuated, drum and shoe type.

Brakes, Parking: Cam actuated, drum and shoe type on rear axles. Spring applied, air released for safety.

Front Axles: Tubular tandem.

Rear Axles: Single reduction with interaxle differential. Ratio 6.17:1.

Suspension: Front axles - four spring mounted tandem with torque rods.

Rear axles - Solid bogie mounted tandem with torque rods.

Transmission: Road Ranger RTO-11613, 13 speeds forward, 3 reverse.

Clutch: Spicer 14" (356mm) two plate with asbestos linings, coaxial torque dampener, upshift clutch brake and air actuation assist.

Radiator: Water to air, tube and fin type core. Thermostatic temperature controlled.

Air Cleaner: Donaldson single-stage primary dry air cleaner with "Duralife" filter media.

Muffler: Donaldson - muffler and resonator.

Electrical: 24 volt system with negative ground. Two 8D batteries with a reserve capacity of 398 min. and CCA at 0°F of 885 amps. Wire harnesses have environmentally sealed Deutsch connectors.

Fuel Tank: FWHA approved steel tank, 80 gal. (303 liter) mounted on right side of carrier, behind front outriggers.

Tires: Front 15:00 R 22.5 18 ply; rear 11:00 x 20 14 ply duals.

See Chart no. 15 for proper tire inflation.



Power Plant

Make:	Detroit Diesel Allison 6L71TA-DDEC
Max. Horsepower:	270 hp (202 kw) @ 2100 rpm
Max. Torque:	850 ft.lbs. (117.5 kg/m) @ 1200 rpm
No. Cylinders:	6
Bore & Stroke:	4.25" (107.9mm) x 5.0" 127mm
Displacement:	426 cu. in. (6.98 liters)
Cycles:	2
Alternator:	Delco 24 volt, 65 amp
Aspiration:	Turbocharged
Air Compressor:	Bendix TU-FLO 501



Performance:

GVW: 77,000 lb (34,920 kg), tires: 15:00 R 22.5 front, 11:00 x 20 rear, counterweight 8000 lbs.

Low gear: 2.2 mph (3.5 km/hr) 35% grade
High gear: 51 mph (82 km/hr) 1.1% grade

Speed and gradeability will vary due to engine performance, vehicle weight and optional tires. Gradeability based on SAE J688.

End Basic Machine

See page 4 for Optional Equipment and Accessories

Optional Equipment and Accessories

ITEM NO.	Attachment Options and Accessories
125	Lattice Extension: 35 ft. (Item 145 included w/ new machine). Swingaway lattice structure with a detachable point section for easy conversion to telescopic type extension with a single metallic sheave. It can be put into operating condition by pivoting from its stored position on right side of boom base section. Self storing pins connect extension to boom head. In the operating position the extension is offset 2° from the main boom. Includes anti-two block material.
135	Telescopic Lattice Extension: 35 ft. to 60 ft. (Item 150 included w/ new machine). Swingaway lattice structure boom extension with a welded four plate telescope section with a single metallic sheave. It can be put into operating condition by pivoting from its stored position on the right side of the boom base section and pinned to the boom head. Telescopic section is then extended on rollers and pinned. The telescopic section can be replaced with a stub head section when extra length is not required. In the operating position the extension is offset 2° from the main boom. Includes anti-two-block material. <i>For performance characteristics see Chart no 1: Crane Range Diagram, and Chart nos. 3, 6, 7, 9, 10 and 11: Load Ratings for Lattice Extension.</i>
140	Offset Mechanism: Pivoting links which allow items 125 and 135 to offset 17° or 30° from the main boom.
145	Material for storing Item 125, 35' extension, on the right side of boom. (For future installation of extension).
150	Material for storing Item 135, 35' to 60' extension, on right side of boom. (For future installation of extension).
160	Auxiliary Boom Point Sheave: Boom point mounted with single metallic sheave, includes anti-two block material.
185	Counterweight: 8,000 lbs. (3630 kg) with removable 7525 lbs. (3414 kg) insert, removable with a self-contained raising or lowering device using the winch. Replaces standard, non-removable 8000 lbs. counterweight.
205	Auxiliary Winch: P&H model 1580, same as main winch, mounted to rear of revolving frame on the counterweight.
220	Wire Rope for Auxiliary Winch: .75" x 460', 8 x 19 spin resistant
230	Drum Turn Indicator: For auxiliary winch, mechanical.
235	Hook Block: 50 ton, 5 sheaves
240	Hook Block: 45 ton, 4 sheaves
245	Hook Block: 20 ton, 1 sheave
255	Weighted Jib Hook: 8.5 ton, with swivel
260	Cable Spooling Device: Main or auxiliary winch drum
265	Independent Winch Control: Two pump circuit to give independent control of main and auxiliary winches.

ITEM NO.	Miscellaneous Options
405	Windshield Washer: Upper
410	Window Wiper: Roof
415	Upper Heater & Defroster: Diesel
420	Upper Heater & Defroster: Propane w/out tank.
435	Vandalism Kit: Lexan Glass
440	Tinted Glass
455	Rotating Beacon: Amber, on roof of cab
460	Floodlight: (1), includes standard alternator
510	Tires: 16:00 R 22.5 18 ply front (4) 12:00 x 20 16 ply rear (8)
550	Spare Wheel & Tire: 15:00 R 22.5 18 ply - front
555	Spare Wheel & Tire: 11:00 x 20 14 ply - rear
560	Spare Wheel & Tire: 16:00 R 22.5 18 ply - front
565	Spare Wheel & Tire: 12:00 x 20 16 ply - rear
625	Pintle Hook: front or rear
635	Cold Weather Starting Aid
645	Tire Inflation Kit

Operational Aids

720	P.A.T. load moment operational aid DS350 microprocessor system - includes load moment device w/ audio-visual warning, rated load, actual load, tare, radius, angle, length and height of boom tip indicators. Includes control lever lockouts (magnetic valve shut-off devices).
730	Krueger (HLAP) boom angle, length, radius indicators with angle preset and audio-visual warning.
745	Krueger load moment system (Mark III). Includes load moment device w/ audio-visual warning, radius, angle, length w/ angle preset.

END OPTIONAL EQUIPMENT

	POUNDS			KILOGRAMS		
	GROSS	FRONT	REAR	GROSS	FRONT	REAR
BASIC CARRIER	33457	15009	18448	15176	6808	8368
BASIC UPPER	5441	448	4993	2468	203	2265
STANDARD EQUIPMENT						
110 FT. 4-SECT. BOOM	17555	13140	4415	7963	5960	2003
BOOM HOIST CYLINDERS	2063	1041	1023	936	472	464
8000 LB. COUNTERWEIGHT	8016	-3226	11241	3636	-1463	5099
MAIN WINCH - MODEL 1580	1080	-301	1381	490	-136	626
MAIN WINCH WIRE ROPE .75" X 515	536	-149	685	243	-68	311
AUX. WINCH OR 1080 LB. COUNTERWEIGHT	1080	-437	1518	490	-198	688
DETROIT DIESEL 6L 71TA ENGINE	4288	4299	-11	1945	1950	-5
FRONT TIRES & RIMS -(4) 15:00R22.5 18 PR	1237	1237	0	561	561	0
REAR TIRES & RIMS -(8) 11:00X20 14 PR	2037	0	2037	924	0	924
MULTI-POSITION SWING LOCK	33	7	26	15	3	12
HYDRAULIC FRONT STABILIZER	465	671	-206	211	304	-93
BASIC MACHINE	77288	31739	45550	35058	14396	20662
ADJUSTMENTS FOR OPTIONS:						
BASIC MACHINE:						
REMOVABLE 7525 LB. CWT. INSERT	-7525	3048	-10573	787	1382	-4796
FRONT TIRES & RIMS - (4) 16:00R22.5 18PR	103	103	0	47	47	0
REAR TIRES & RIMS - (8) 12:00X20 16 PR	170	0	170	77	0	77
MULTI POSITION SWING LOCK	33	7	26	15	3	12
ADDITIONS FOR OPTIONS:						
ATTACHMENTS:						
35 FT. BOOM EXTENSION	1735	1353	382	787	614	173
35 FT. - 60 FT. BOOM EXTENSION	2899	2150	750	1315	975	340
BOOM EXTENSION OFFSET INST.	201	331	-131	91	150	-59
AUX. BOOM POINT SHEAVE	152	167	-115	69	121	-52
45 TON HOOK BLOCK - AT FRNT. TOW HOOK	899	1429	-529	408	648	-240
50 TON HOOK BLOCK - AT FRNT. TOW HOOK	946	1502	-557	429	681	-252
20 TON HOOK BLOCK - ON REAR DECK	580	-184	764	263	-83	346
8.5 TON BALL HOOK - ON REAR DECK	265	-84	348	120	-38	158
AUX. WINCH ROPE .75" X 460'	487	-197	685	221	-89	310
UPPER:						
AUX. WINCH PLUMBING & CONTROLS	82	-12	94	37	-6	43
DIESEL HEATER	53	-1	54	24	0	24
PROPANE HEATER	55	-1	56	25	0	25
PROPANE TANK - FULL	49	-2	51	22	-1	23
FLOODLIGHTS	35	21	15	16	9	7
CARRIER:						
PINTLE HOOK	26	-10	37	12	-5	17
AIR DRYER	37	19	18	17	9	8

Area of Operations

ON OUTRIGGERS

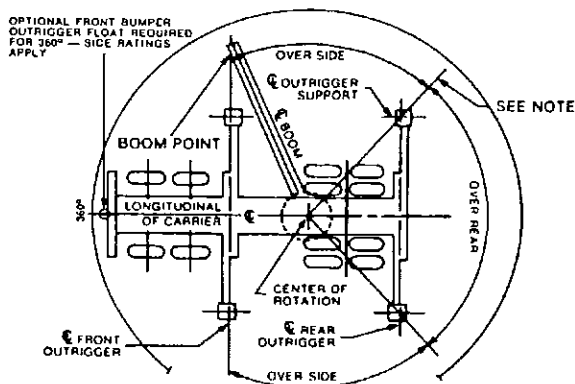

ON RUBBER

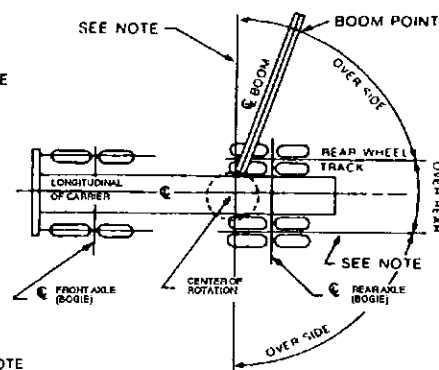

NOTE

THESE LINES DETERMINE ANY LIMITING POSITION OF ANY LOAD FOR OPERATION WITHIN WORKING AREAS INDICATED

CHART

1

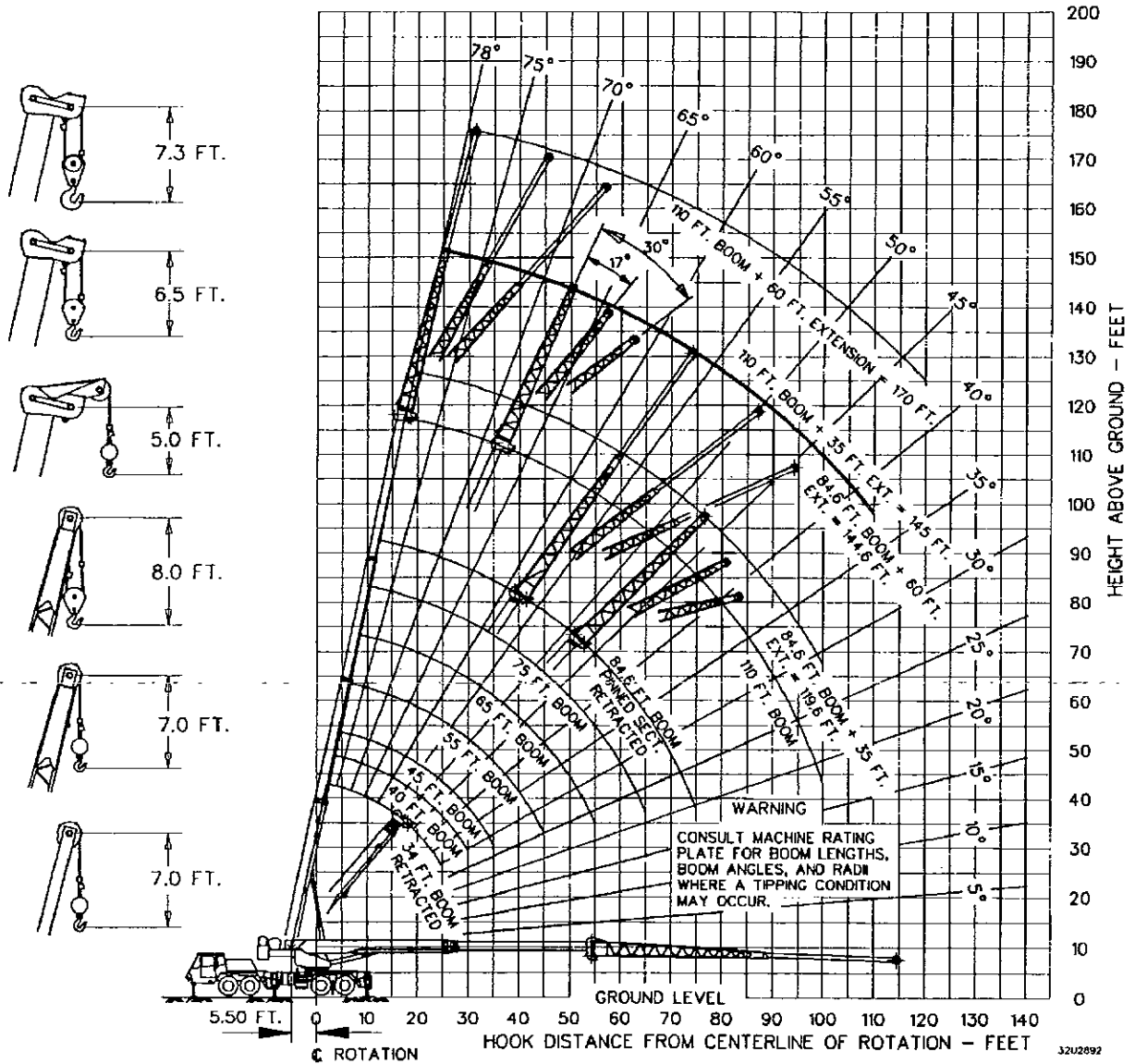

Crane Range Diagram

Load Ratings - on Outriggers - with 8000 lbs. Counterweight PCSA Class 10-208

OPERATING RADIUS IN FEET		RATED LOADS IN POUNDS ON OUTRIGGERS																OPERATING RADIUS IN FEET	
		POWERED BOOM LENGTH IN FEET - MANUAL RETRACTED																	
		34 FT.		40 FT.		45 FT.		55 FT.		65 FT.		75 FT.		84.66 FT.					
BOOM ANGLE	SIDE	RATED LOAD POUNDS		BOOM ANGLE	SIDE	RATED LOAD POUNDS		BOOM ANGLE	SIDE	RATED LOAD POUNDS		BOOM ANGLE	SIDE	RATED LOAD POUNDS					
		REAR	FRONT			REAR	FRONT			REAR	FRONT			REAR	FRONT				
10	65	100000	70	82000	72	81000	76	75000								10			
12	62	86000	67	81500	70	76500	74	69000								12			
15	56	71000	62	71000	65	70000	71	62000								15			
20	45	54000	53	54000	58	54000	65	53000								20			
25	29	42000	43	42000	50	41900	59	41700								25			
30			30	33700	40	33600	52	33500								30			
35					28	27100	27100	45	27100	27100	54	27100	27100	60	26400	64	22900	35	
40								37	20800	21200	48	20800	21200	55	20800	21200	60	20400	40
45								26	16100	16800	41	16100	16800	50	16100	16800	56	16100	45
50											34	13000	13700	45	13000	13700	52	13000	50
55											24	10500	11300	39	10500	11300	47	10500	55
60														32	8400	9200	42	8400	60
65														22	6900	7600	36	6900	65
70																29	5800	6300	70
75																20	4500	5200	75
80																			80
85																			85

**CHART
2**

**CHART
3**

LOAD RATINGS IN POUNDS WITH OUTRIGGERS EXTENDED																
PINNED SECTION EXTENDED				LATTICE EXTENSION WITH PINNED SECTION RETRACTED								LATTICE EXTENSION WITH PINNED SECTION EXTENDED				
OPERATING RADIUS IN FEET	BOOM ANGLE	RATED LOAD IN POUNDS		35 FT. TELESCOPIC		60 FT. TELESCOPIC		35 FT. TELESCOPIC		60 FT. TELESCOPIC		35 FT. TELESCOPIC		60 FT. TELESCOPIC		
		SIDE	REAR	SIDE	REAR	SIDE	REAR	SIDE	REAR	SIDE	REAR	SIDE	REAR	SIDE	REAR	
25	77	21500		25	78	17000		25	78	16400		25				
30	74	19600		30	76	15600		30	78	15100		30				
35	72	17800		35	73	14500		35	73	13900		35				
40	69	16100		40	71	13500		40	71	12900		40				
45	66	14700		45	68	12600		45	68	12000		45	73	10100		
50	63	13400		50	66	11800		50	66	11200		50	70	9300		
55	60	12200	12400	55	63	11100		55	63	10400		55	69	8500		
60	57	10000	10700	60	60	10400		60	60	9800		60	67	7900		
65	53	8500	9200	65	57	8900	9500	65	57	8100	8800	65	65	7300		
70	50	7200	7900	70	54	7600	8200	70	54	6800	7400	70	62	5200		
75	48	8100	8700	75	51	6400	7100	75	51	5700	6300	75	60	5100		
80	42	5100	5800	80	48	5500	6100	80	48	4700	5300	80	57	4900		
85	38	4300	4900	85	44	4600	5200	85	44	3900	4400	85	55	4600		
90	33	3600	4200	90	40	3900	4500	90	40	3100	3700	90	52	4400		
100	19	2400	3000	100	32	2700	3200	100	32	1900	2500	100	47	3200	3700	
				110	19	-	2200						110	41	2200	2700
													120	34	-	1800

**CHART
4**

DEDUCTIONS TO BE MADE FROM LOAD RATINGS IN POUNDS					
DESCRIPTION	WITHOUT HOOR BLOCK ON BOOM POINT	HOOR BLOCK ON POWERED BOOM POINT			
		8.5 - 20 TON	45-50 TON	8.5 - 20 TON WITH AUXILIARY SHEAVE	45-50 TON WITH AUXILIARY SHEAVE
HOISTING LOAD FROM POWERED BOOM					
35 FT. LATTICE EXTENSION					
ERECTED ONLY	---	350	950	740	1100
8.5 TON BALL	---	700	1100	850	1250
20 TON BLOCK	---	3550	3900	3700	4050
20 TON BLOCK	---	4700	5050	4850	5200
20 TON BLOCK	---	6000	6350	6150	6500
35 FT. TELESCOPIC LATTICE EXTENSION					
ERECTED ONLY	---	700	1050	850	1200
8.5 TON BALL	---	5500	5850	5650	6000
20 TON BLOCK	---	6650	7000	6800	7150
20 TON BLOCK	---	7950	8350	8100	8500
60 FT. TELESCOPIC LATTICE EXTENSION					
ERECTED ONLY	---	5500	5850	5650	6000
8.5 TON BALL	---	7100	7450	7250	7600
20 TON BLOCK	---	8900	9250	9050	9400
HOISTING LOAD FROM EXTENSION					
35 FT. LATTICE EXTENSION					
8.5 TON BALL	---	270	650	850	950
20 TON BLOCK	---	580	950	1150	1250
35 FT. TELESCOPIC LATTICE EXTENSION					
8.5 TON BALL	---	270	650	900	1000
20 TON BLOCK	---	580	950	1200	1300
60 FT. TELESCOPIC LATTICE EXTENSION					
8.5 TON BALL	---	270	600	800	850
20 TON BLOCK	---	580	900	1100	1000

**CHART
5**

MAIN HOIST REEVING										
.75" WIRE ROPE BREAKING STRENGTH 58,800 LBS. 6 x 25 FW IWRC										
PARTS OF LINE	1	2	3	4	5	6	7	8	9	10
MAXIMUM LOAD	11000	22000	33000	44000	55000	66000	77000	88000	99000	100000
AUXILIARY HOIST REEVING										
.75" WIRE ROPE BREAKING STRENGTH 51,800 LBS. 8 x 19 SPIN RESISTANT										
PARTS OF LINE	1	2	3	4	5	6	7	8	9	10
MAXIMUM LOAD	10000	10000	30000	40000	50000	60000	70000	80000	90000	100000

Definitions:
 1. Operating radius is the horizontal distance from the axis of rotation before loading to the center of the vertical hoist line or tackle with load applied.
 2. Loaded boom angle, as shown in the column headed by is the included angle between the horizontal and the longitudinal axes of the boom base after lifting rated load at rated radius.

CHART 6

Load Ratings - on Outriggers - 8000 lbs Counterweight Offset Lattice Extension

LOAD RATINGS IN POUNDS FOR 17° OFFSET WITH OUTRIGGERS EXTENDED

LATTICE EXTENSION WITH PINNED SECTION RETRACTED						LATTICE EXTENSION WITH PINNED SECTION EXTENDED							
OPERATING RADIUS IN FEET	35 FT.		35 FT. TELESCOPIC		60 FT. TELESCOPIC		OPERATING RADIUS IN FEET	35 FT.		35 FT. TELESCOPIC		60 FT. TELESCOPIC	
	FOR ALL BOOM LENGTHS 69 TO 119.6 FT.							FOR ALL BOOM LENGTHS 94 TO 144.6 FT.					
	LOADED BOOM ANGLE	RATED LOAD IN POUNDS		LOADED BOOM ANGLE	RATED LOAD IN POUNDS			LOADED BOOM ANGLE	RATED LOAD IN POUNDS		LOADED BOOM ANGLE	RATED LOAD IN POUNDS	
	SIDE	REAR	SIDE	REAR	SIDE	REAR		SIDE	REAR	SIDE	REAR	SIDE	REAR
35	77	11100	35	77	10400	35							
40	74	10400	40	75	9900	40							
45	72	9900	45	72	9300	45	78	5400	45	77	9700		
50	69	9500	50	69	8900	50	76	5200	50	75	9000		
55	67	9100	55	67	8500	55	74	5100	55	73	8300		
60	64	8700	60	64	8100	60	72	4900	60	71	7700		
65	61	8400	65	61	7800	65	70	4700	65	68	7200		
70	58	8100	70	58	7500	70	67	4500	70	66	6700		
75	55	7000	75	55	6300	75	65	4300	75	64	6200		
80	52	6000	80	52	5200	80	63	4100	80	61	5800		
85	48	5100	85	48	4300	85	60	3900	85	59	5400		
90	44	4300	90	44	3500	90	58	3700	90	56	4900	5100	
100	35	3000	100	35	2200	100	52	3500	100	51	3600	4100	
110	21	-	110	21	2300	110	46	2700	110	44	2500	3000	
120			120	39	-	120	39	-	120	37	-	2100	

CHART 7

LOAD RATINGS IN POUNDS FOR 30° OFFSET WITH OUTRIGGERS EXTENDED

LATTICE EXTENSION WITH PINNED SECTION RETRACTED						LATTICE EXTENSION WITH PINNED SECTION EXTENDED							
OPERATING RADIUS IN FEET	35 FT.		35 FT. TELESCOPIC		60 FT. TELESCOPIC		OPERATING RADIUS IN FEET	35 FT.		35 FT. TELESCOPIC		60 FT. TELESCOPIC	
	FOR ALL BOOM LENGTHS 69 TO 119.6 FT.							FOR ALL BOOM LENGTHS 94 TO 144.6 FT.					
	LOADED BOOM ANGLE	RATED LOAD IN POUNDS		LOADED BOOM ANGLE	RATED LOAD IN POUNDS			LOADED BOOM ANGLE	RATED LOAD IN POUNDS		LOADED BOOM ANGLE	RATED LOAD IN POUNDS	
	SIDE	REAR	SIDE	REAR	SIDE	REAR		SIDE	REAR	SIDE	REAR	SIDE	REAR
35			35			35							
40	78	8900	40	78	8300	40							
45	75	8500	45	75	7900	45							
50	72	8200	50	72	7600	50							
55	70	8000	55	70	7400	55							
60	67	7700	60	67	7100	60	76	4200	60	73	7100		
65	64	7500	65	64	6900	65	74	4000	65	71	6600		
70	61	7300	70	61	6700	70	72	3800	70	68	6200		
75	57	7200	75	58	6600	75	69	3700	75	66	5900		
80	54	6300	80	54	5600	80	67	3600	80	63	5600		
85	50	5400	85	50	4600	85	64	3500	85	61	5300		
90	46	4500	90	46	3800	90	62	3400	90	58	5000		
100	36	3100	100	36	2300	100	56	3200	100	52	3800	4300	
110	19	1800	110	19	2300	110	49	3000	110	46	2700	3200	
120			120	41	2000	120	41	2000	120	38	1800	2200	

- NOTES:**
- SEE MAIN LOAD RATING CHART ON OUTRIGGERS FOR WARNINGS, DEFINITIONS, INFORMATION AND REEVING.
 - FOR BUCKET RATINGS ON 60 FT. EXTENSION, DEDUCT 20% FROM LOAD RATINGS.
 - STABILITY RATINGS DO NOT EXCEED 85% OF TIPPING LOADS.
 - WHEN BOOM IS NOT FULLY EXTENDED USE ONLY BOOM ANGLES, NOT OPERATING RADIUS TO DETERMINE LOAD RATING.
 - FOR BOOM ANGLES NOT SHOWN, USE RATING OF NEXT LOWER BOOM ANGLE.
 - 8000 LB. STANDARD COUNTERWEIGHT OR 8000 LB. OPTIONAL CWT. INCLUDING 7525 LB. REMOVABLE WT.

WARNINGS:

A TIPPING CONDITION WILL OCCUR (WITH OR WITHOUT HOOK BLOCK) WITH 35 FT. OR 60 FT. BOOM EXTENSION ERECTED, IF MAXIMUM OPERATING RADIUS SHOWN WITH LOAD RATING FOR RESPECTIVE OPERATING CONFIGURATION IS EXCEEDED.

Load Ratings - on Outriggers - PCSA Class 10-156

8000 lbs. Counterweight with 7525 lb. Insert Removed

OPERATING		RATED LOADS IN POUNDS ON OUTRIGGERS												OPERATING			
		POWERED BOOM LENGTH IN FEET - MANUAL RETRACTED															
		34 FT.		40 FT.		45 FT.		55 FT.		65 FT.		75 FT.				84.66 FT.	
LOADED BOOM ANGLE °	RATED LOAD POUNDS		LOADED BOOM ANGLE °	RATED LOAD POUNDS		LOADED BOOM ANGLE °	RATED LOAD POUNDS		LOADED BOOM ANGLE °	RATED LOAD POUNDS		LOADED BOOM ANGLE °	RATED LOAD POUNDS		LOADED BOOM ANGLE °	RATED LOAD POUNDS	
	SIDE	REAR		SIDE	REAR		SIDE	REAR		SIDE	REAR		SIDE	REAR		SIDE	REAR
10	66	10000	70	82000	72	81000	76	71500									10
12	62	52700	67	81500	70	78500	74	66500	77	57000							12
15	58	55500	62	85500	65	85400	71	59000	74	51000	77	45000					15
20	44	50000	53	49800	58	49700	65	49600	66	45000	73	39300	75	34700			20
25	29	38900	43	38900	50	38800	59	38800	65	38500	66	34400	72	29900			25
30			30	28600	29100	40	28600	29100	52	28400	29100	59	28600	29100	68	26100	30
35						28	20700	21800	45	20700	21800	54	20700	21800	64	20700	35
40									36	15400	16800	48	15500	16800	55	15800	40
45									28	11800	13100	41	11800	13100	50	11800	45
50												34	9200	10500	45	9200	50
55												24	7200	8400	38	7200	55
60															31	5500	6000
65															22	4200	5300
70																29	3200
75																20	2300
80																	
85																	

CHART 8

CHART 9

LOAD RATINGS IN POUNDS WITH OUTRIGGERS EXTENDED														
PINNED SECTION EXTENDED			LATTICE EXTENSION WITH PINNED SECTION RETRACTED						LATTICE EXTENSION WITH PINNED SECTION EXTENDED					
OPERATING	LOADED BOOM ANGLE ONLY	RATED LOAD IN POUNDS	35 FT.		35 FT. TELESCOPIC		60 FT.		35 FT.		35 FT. TELESCOPIC		60 FT. TELESCOPIC	
			SIDE	REAR	SIDE	REAR	SIDE	REAR	SIDE	REAR	SIDE	REAR	SIDE	REAR
25	77	21500	25	78	17000	25	78	18400	25			25		
30	74	19600	30	76	15600	30	76	16100	30	76	73000	30		
35	72	17800	35	73	14500	35	73	13900	35	76	7100	35	77	
40	69	16100	40	71	13500	40	71	12900	40	74	6800	40	75	
45	66	13800	45	68	12800	45	68	12000	45	72	6300	45	73	
50	63	10800	50	65	11300	50	65	10600	50	70	6100	50	71	
55	60	8800	55	63	9200	55	63	8600	55	68	5700	55	68	
60	58	7100	60	60	7600	60	60	6800	60	66	5500	60	67	
65	55	5800	65	57	6200	65	57	5600	65	64	5400	65	65	
70	49	4700	70	54	5100	70	54	4400	70	62	5200	70	63	
75	46	3800	75	51	4200	75	51	3400	75	60	4800	75	60	
80	42	3000	80	47	3400	80	47	2800	80	57	3900	80	58	
85	37	2400	85	44	2700	85	44	1900	85	55	3200	85	55	
90	32	1800	90	40	2100	90	40	1500	90	52	2600	90	52	
			100	31	1800				100	47	2300	100	47	

NOTE:

- WHEN BOOM IS NOT FULLY EXTENDED, USE ONLY BOOM ANGLES, NOT OPERATING RADIUS TO DETERMINE LOAD RATING.
- FOR BOOM ANGLES NOT SHOWN, USE RATING OF NEXT LOWER BOOM ANGLE.
- FOR BUCKET RATINGS ON 60 FT. EXTENSION, DEDUCT 20% FROM LOAD RATINGS.

WARNING:

A TIPPING CONDITION WILL OCCUR (WITH OR WITHOUT A HOOK BLOCK) WITH BOOM PINNED SECTION EXTENDED, OR WITH THE 35 FT. OR 60 FT. BOOM EXTENSION ERECTED, IF MAXIMUM OPERATING RADIUS SHOWN WITH LOAD RATING FOR RESPECTIVE OPERATING CONFIGURATION IS EXCEEDED.

INFORMATION:

- CRANE LOAD RATINGS DO NOT EXCEED 85% OF TIPPING.
- RATINGS ABOVE THE HEAVY LINE ARE BASED ON THE MACHINE'S HYDRAULIC OR STRUCTURAL COMPETENCE AND NOT ON MACHINE STABILITY.
- DEDUCTIONS MUST BE MADE FROM RATED LOADS FOR STOWED LATTICE EXTENSION, OPTIONAL ATTACHMENTS, HOOKS AND HOOKBLOCKS (SEE DEDUCTIONS CHART). WEIGHTS OF SLINGS AND ALL OTHER LOAD HANDLING DEVICES SHALL BE CONSIDERED A PART OF THE LOAD.
- CRANE LOAD RATINGS WITH OUTRIGGERS ARE BASED ON OUTRIGGERS FULLY EXTENDED AND SET TO A DISTANCE OF 11 FEET 9 1/4 INCH FROM THE LONGITUDINAL AXIS OF THE CARRIER TO THE OUTRIGGER FLOAT PIVOT CONNECTION WITH ALL LOAD REMOVED FROM CARRIER WHEELS.

WARNINGS:

- LOADED BOOM ANGLES AT SPECIFIED BOOM LENGTHS GIVE ONLY AN APPROXIMATION OF THE OPERATING RADIUS. THE BOOM ANGLE BEFORE LOADING SHOULD BE GREATER TO ACCOUNT FOR DEFLECTIONS. DO NOT EXCEED THE OPERATING RADIUS FOR RATED LOADS.
- POSITIONING OR OPERATION OF POWERED BOOM LENGTHS AT RADII BEYOND THE MAXIMUMS OR MINIMUMS SHOWN, IS NOT INTENDED OR APPROVED.
- POSITIONING OR OPERATION OF LATTICE EXTENSIONS AT BOOM ANGLES BEYOND THE MAXIMUMS OR MINIMUMS SHOWN, IS NOT INTENDED OR APPROVED.
- FOR POWERED BOOM LENGTHS NOT SHOWN, USE RATING OF NEXT LONGER POWERED BOOM. FOR LOAD RADII NOT SHOWN, USE RATING OF NEXT LONGER RADIUS.
- CRANE LOAD RATINGS ON OUTRIGGERS ARE BASED ON FREELY SUSPENDED LOADS WITH THE MACHINE LEVELED AND STANDING ON A FIRM UNIFORM SUPPORTING SURFACE. NO ATTEMPT SHALL BE MADE TO MOVE A LOAD HORIZONTALLY ON THE GROUND IN ANY DIRECTION.
- PRACTICAL WORKING LOADS DEPEND ON SUPPORTING SURFACE, WIND, AND OTHER FACTORS AFFECTING STABILITY, HAZARDOUS SURROUNDINGS, EXPERIENCE OF PERSONNEL, AND PROPER HANDLING. ALL OF WHICH MUST BE TAKEN INTO ACCOUNT BY THE OPERATOR.
- THE MAXIMUM LOAD WHICH MAY BE TELESCOPED IS LIMITED BY HYDRAULIC PRESSURE, BOOM ANGLE, AND POWERED BOOM LUBRICATION. IT IS SAFE TO ATTEMPT TO TELESCOPE ANY LOAD WITHIN THE LIMITS OF THE LOAD RATING CHART.
- WHEN LIFTING A LOAD ALL SECTIONS OF POWERED BOOM MUST BE EQUALLY EXTENDED WITHIN ONE FOOT.

NOTES:

OPERATION OF THIS EQUIPMENT IN EXCESS OF RATED LOADS AND DISREGARD OF INSTRUCTIONS IS AN UNSAFE PRACTICE AND WILL RESULT IN DENIAL OF WARRANTY CLAIMS.

Load Ratings - on Outriggers - Offset Lattice Extension

8000 lbs. Counterweight with 7525 lb. Insert Removed

CHART 10

LOAD RATINGS IN POUNDS FOR 17° OFFSET WITH OUTRIGGERS EXTENDED														
LATTICE EXTENSION WITH PINNED SECTION RETRACTED						LATTICE EXTENSION WITH PINNED SECTION EXTENDED								
OPERATING RADIUS IN FT	35 FT.		35 FT. TELESCOPIC		60 FT. TELESCOPIC		OPERATING RADIUS IN FT	35 FT.		35 FT. TELESCOPIC		OPERATING RADIUS IN FT	60 FT. TELESCOPIC	
	FOR ALL BOOM LENGTHS 69 TO 119.6 FT.		FOR ALL BOOM LENGTHS 69 TO 119.6 FT.		FOR ALL BOOM LENGTHS 94 TO 144.6 FT.			FOR ALL BOOM LENGTHS 94.3 TO 145 FT.		FOR ALL BOOM LENGTHS 94.3 TO 145 FT.			FOR ALL BOOM LENGTHS 119.3 TO 170 FT.	
	LOADED BOOM ANGLE °	RATED LOAD IN POUNDS	LOADED BOOM ANGLE °	RATED LOAD IN POUNDS	LOADED BOOM ANGLE °	RATED LOAD IN POUNDS		LOADED BOOM ANGLE °	RATED LOAD IN POUNDS	LOADED BOOM ANGLE °	RATED LOAD IN POUNDS		LOADED BOOM ANGLE °	RATED LOAD IN POUNDS
	SIDE	REAR	SIDE	REAR	SIDE	REAR		SIDE	REAR	SIDE	REAR	SIDE	REAR	
35	77	11100	35	77	10400	35						35		
40	74	10400	40	75	9900	40						40		
45	72	9900	45	72	9300	45	78	5400	45	77	9100	45		
50	69	9500	50	69	8900	50	76	5200	50	75	9000	50		
55	67	9100	55	67	8500	55	74	5100	55	73	8300	55	78	5200
60	64	8400	60	64	7700	60	72	4900	60	70	7700	60	76	5000
65	61	7000	65	61	6300	65	70	4700	65	68	7200	65	75	4800
70	58	5800	70	58	5100	70	67	4500	70	66	6300	70	73	4600
75	55	4800	75	55	4000	75	65	4300	75	64	5300	75	71	4400
80	51	3900	80	51	3100	80	63	4100	80	61	4400	80	69	4100
85	48	3100	85	48	2400	85	60	3900	85	58	3700	85	67	3900
90	44	2500	90	44	2500	90	58	3300	90	55	3000	90	65	3600
100	35	-	100	35	-	100	52	2200	100	50	1900	100	61	2400
						110	46	-	110	50	1900	110	56	2100

CHART 11

LOAD RATINGS IN POUNDS FOR 30° OFFSET WITH OUTRIGGERS EXTENDED														
LATTICE EXTENSION WITH PINNED SECTION RETRACTED						LATTICE EXTENSION WITH PINNED SECTION EXTENDED								
OPERATING RADIUS IN FT	35 FT.		35 FT. TELESCOPIC		60 FT. TELESCOPIC		OPERATING RADIUS IN FT	35 FT.		35 FT. TELESCOPIC		OPERATING RADIUS IN FT	60 FT. TELESCOPIC	
	FOR ALL BOOM LENGTHS 69 TO 119.6 FT.		FOR ALL BOOM LENGTHS 69 TO 119.6 FT.		FOR ALL BOOM LENGTHS 94 TO 144.6 FT.			FOR ALL BOOM LENGTHS 94.3 TO 145 FT.		FOR ALL BOOM LENGTHS 94.3 TO 145 FT.			FOR ALL BOOM LENGTHS 119.3 TO 170 FT.	
	LOADED BOOM ANGLE °	RATED LOAD IN POUNDS	LOADED BOOM ANGLE °	RATED LOAD IN POUNDS	LOADED BOOM ANGLE °	RATED LOAD IN POUNDS		LOADED BOOM ANGLE °	RATED LOAD IN POUNDS	LOADED BOOM ANGLE °	RATED LOAD IN POUNDS		LOADED BOOM ANGLE °	RATED LOAD IN POUNDS
	SIDE	REAR	SIDE	REAR	SIDE	REAR		SIDE	REAR	SIDE	REAR	SIDE	REAR	
35			35			35						35		
40	78	8900	40	78	8300	40						40		
45	75	8500	45	75	7900	45						45		
50	72	8200	50	72	7600	50						50		
55	70	8000	55	70	7400	55						55		
60	67	7700	60	67	7100	60	76	4200	60	73	7100	60		
65	64	7500	65	64	6900	65	74	4000	65	71	6900	65	78	4100
70	61	6300	70	61	5600	70	72	3800	70	68	6200	70	76	3900
75	57	5200	75	57	4500	75	69	3700	75	66	5800	75	75	3800
80	54	4300	80	54	3500	80	67	3600	80	63	4900	80	73	3700
85	50	3400	85	50	2700	85	64	3500	85	61	4100	85	71	3500
90	46	2700	90	46	2000	90	62	3400	90	58	3400	90	69	3300
100			100			100	56	2600	100	52	2200	100	64	2900
						110	49	-	110	45	1900	110	59	1900

- NOTES:**
- SEE MAIN LOAD RATING CHART ON OUTRIGGERS FOR WARNINGS, DEFINITIONS, INFORMATION AND REEVING.
 - FOR BUCKET RATINGS ON 60 FT. EXTENSION, DEDUCT 20% FROM LOAD RATINGS.
 - STABILITY RATINGS DO NOT EXCEED 85% OF TIPPING LOADS.
 - WHEN BOOM IS NOT FULLY EXTENDED USE ONLY BOOM ANGLES, NOT OPERATING RADIUS TO DETERMINE LOAD RATING.
 - FOR BOOM ANGLES NOT SHOWN, USE RATING OF NEXT LOWER BOOM ANGLE.
 - 8000 LB. COUNTERWEIGHT WITH 7525 LB. WEIGHT REMOVED.

WARNINGS:
 A TIPPING CONDITION WILL OCCUR (WITH OR WITHOUT A HOOK BLOCK) WITH 35 FT. OR 60 FT. BOOM EXTENSION ERECTED, IF MAXIMUM OPERATING RADIUS SHOWN WITH LOAD RATING RESPECTIVE OPERATING CONFIGURATION IS EXCEEDED

On Rubber Ratings

With 8000 lbs. Counterweight

CHART 12

LOAD RATINGS IN POUNDS					
OPERATING RADIUS F.T.	11.00 X 20-14 PR TIRES 12.00 X 20-16 PR TIRES				OPERATING RADIUS F.T.
	STATIONARY		TRAVEL RATINGS OVER REAR		
	OVER REAR	OVER SIDE	CREEP	2.5 MPH	
10	35200	25900	35200	28600	10
12	30500	22000	30500	25500	12
15	26100	15200	26100	22300	15
20	20900	8700	20900	17700	20
25	14800	5200	14800	14400	25
30	10700	3000			30
35	7900				35
40	5900				40
45	4300				45
50	3100				50

8000 lbs Counterweight
with 7525 lb. Insert Removed

CHART 13

LOAD RATINGS IN POUNDS					
OPERATING RADIUS F.T.	11.00 X 20-14 PR TIRES 12.00 X 20-16 PR TIRES				OPERATING RADIUS F.T.
	STATIONARY		TRAVEL RATINGS OVER REAR		
	OVER REAR	OVER SIDE	CREEP	2.5 MPH	
10	31200	20300	31200	26700	10
12	27200	14100	27200	23100	12
15	23500	8800	23500	19800	15
20	16500	4200	16500	15700	20
25	11100	1800	11100	11100	25
30	7700				30
35	5400				35
40	3700				40
45	2400				45
50	1400				50

CHART 14

DEDUCTIONS TO BE MADE FROM LOAD RATINGS IN POUNDS				
DESCRIPTION	HOOK BLOCK ON POWERED BOOM POINT			
	8.5-20 TON	45-50 TON	8.5-20 TON WITH AUX SHEAVE	45-50 TON WITH AUX SHEAVE
HOOK BLOCK WEIGHT	580	950	740	1100
STOWED LATTICE EXT.	35 FT. BOOM EXTENSION	900	1300	1100
	60 FT. TELESCOPIC BOOM EXTENSION	1100	1450	1250

NOTE: LOAD DEDUCTIONS APPLY ONLY TO P&H SUPPLIED EQUIPMENT.

WARNINGS:

1. CRANE LOAD RATINGS WITHOUT OUTRIGGERS DEPENDS ON TIRE CAPACITY AND CONDITION OF TIRES INFLATED PER TABLE.
2. WHEN TRANSPORTING A LOAD, MACHINE MUST BE ON FIRM, LEVEL SURFACE WITH MECHANICAL HOUSELOCK ENGAGED. THE LOAD MUST BE CENTERED OVER REAR OF MACHINE AND RESTRAINED FROM SWINGING. SEE AREAS OF OPERATION PLATE FOR WORKING RANGES.
3. LIFT LOADS WITH MINIMUM BOOM LENGTH; DO NOT EXCEED 65 FEET BOOM LENGTH WHEN LIFTING ON TIRES.
4. DO NOT ATTEMPT LIFTS ON TIRES WITH EXTENSION ERECTED.
5. MAXIMUM RECOMMENDED BOOM ANGLE ON TIRES IS 66° WITHOUT LOAD.

INFORMATION:

1. DEDUCTIONS MUST BE MADE FROM RATED LOADS FOR STOWED LATTICES EXTENSION, OPTIONAL ATTACHMENTS, HOOKS AND HOOKBLOCKS. (SEE DEDUCTION CHART). WEIGHTS OF SLINGS, AND ALL OTHER LOAD HANDLING DEVICES SHALL BE CONSIDERED A PART OF THE LOAD.
2. RATINGS ABOVE THE HEAVY LINE ARE BASED ON STRUCTURAL COMPETENCE AND NOT ON MACHINE STABILITY.
3. IT IS RECOMMENDED THAT OUTRIGGERS BE EXTENDED AS FAR AS POSSIBLE AND CLEAR OF GROUND WHEN LIFTING ON TIRES.
4. STABILITY RATINGS DO NOT EXCEED 75% OF TIPPING LOADS.

DEFINITIONS:

1. CREEP IS MOTION FOR LESS THAN 200 FT. IN A 30 MINUTE PERIOD AND NOT EXCEEDING 1 M.P.H.

NOTES:

OPERATION OF THIS EQUIPMENT IN EXCESS OF RATED LOADS AND DISREGARD OF INSTRUCTIONS IS AN UNSAFE PRACTICE AND WILL RESULT IN DENIAL OF WARRANTY CLAIMS.

CHART 15

TIRE INFLATION			
SIZE	STATIC PSI	CREEP PSI	2.5 MPH PSI
11.00X20-14 PR	110	110	110
12.00X20-16 PR	115	115	115
15.0RX22.5-18PR	130	130	130
16.5RX22.0-18PR	125	125	125

Dimensions

NOTE:
 DIMENSIONS ARE WITH STANDARD FRONT TIRE SIZE: 15:00 R 22.5
 AND STANDARD REAR TIRE SIZE: 11:00 X 20
 WITH OPTION 16:50 R 22.5 FRONT TIRES - ADD 0.87" (22MM) TO HEIGHT DIMENSIONS
 WITH OPTION 12:00 X 20 REAR TIRES - ADD 0.67" (17MM) TO HEIGHT DIMENSIONS

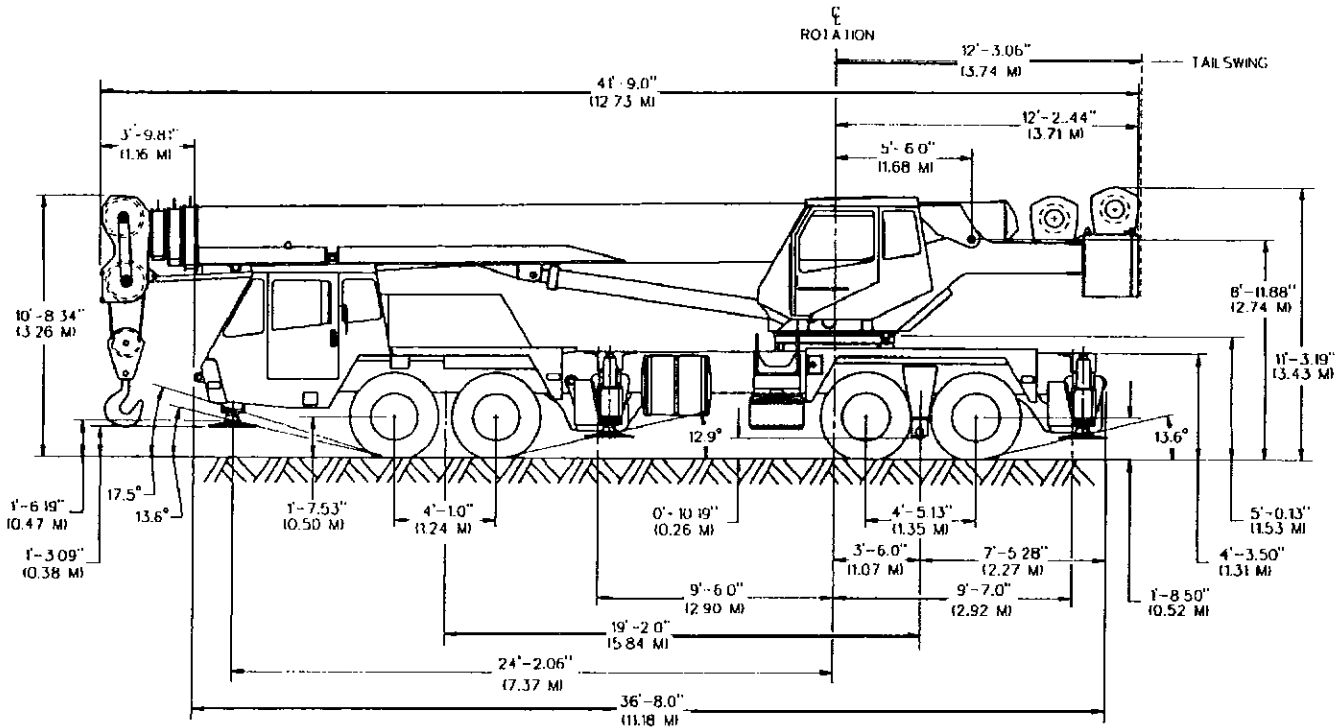
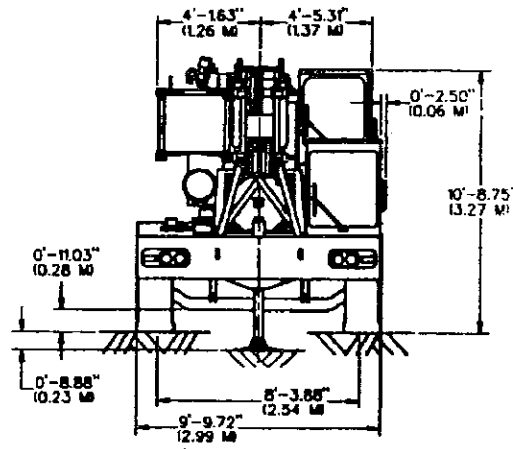
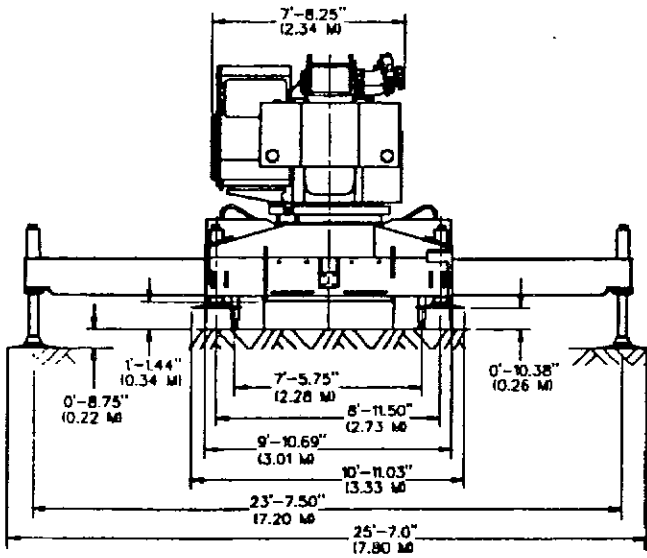

	15:00 x 22.5	16:50 x 22.5
VEHICLE TURNING DIAMETER - TIRE CLEARANCE	85.86 FT. (26.17 M)	93.63 FT. (28.54 M)
VEHICLE CLEARANCE DIA. - TIRE CLEARANCE WITH CURB	87.11 FT. (26.55 M)	94.86 FT. (28.94 M)
CARRIER CLEARANCE	95.83 FT. (29.14 M)	102.80 FT. (31.33 M)
BOOM CLEARANCE	94.43 FT. (28.78 M)	101.83 FT. (30.76 M)
EXTENSION CLEARANCE	96.43 FT. (30.00 M)	105.26 FT. (32.09 M)



NOTE: All designs, specifications and components of the equipment described above are subject to change at the manufacturer's sole discretion at any time and without advance notice. Data published herein is informational in nature and shall not be construed to warrant suitability of the machine for any particular purpose as performance may vary with conditions encountered. The only warranty applicable is our standard warranty for this machine.

Address Inquiries to:



P.O. Box 260002
 Conway, SC 29526-2602
 USA