

Mobile Crane Grue automotrice

LTM 1150/1

Technical Data
Caractéristiques techniques

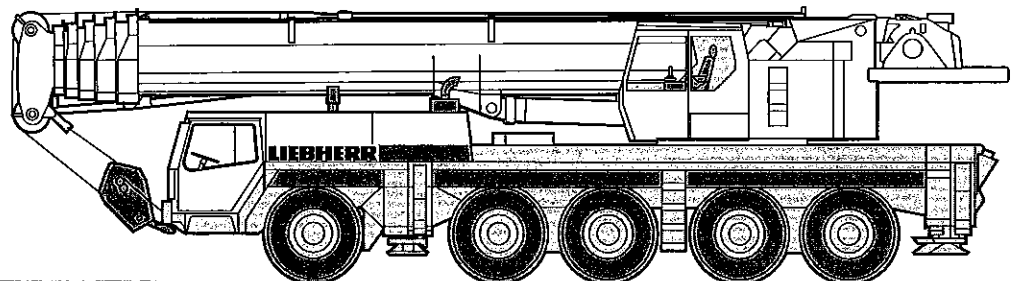

LIEBHERR

Lifting capacities on telescopic boom

Forces de levage à la flèche télescopique

		41 ft - 184 ft		360°		110200 lbs		85%																				
		41 ft		54 ft		67 ft		80 ft		94 ft		107 ft		120 ft		133 ft		146 ft		159 ft		172 ft		184 ft				
ft		*																								ft		
9			269																								9	
10		352	266																									10
11		281	253	207																								11
12		237	237	207																								12
13		221	221	207	202	163																						13
14		208	208	198	192	163	133																					14
15		196	196	188	182	163	133																					15
16		189	189	181	175	163	133	101																				16
17		181	181	174	168	160	132	101																				17
18		175	175	168	162	155	131	101	67																			18
20		162	162	156	150	145	128	101	84																			20
22		151	151	146	140	136	123	101	84	61																		22
24		140	140	137	132	127	117	100	83.5	66																		24
26		130	130	128	124	119	116	99.5	82.5	66.5	49.5																	26
28		119	119	120	117	113	111	96.5	80	66.5	51.4																	28
30		108	108	112	110	107	107	93.5	77.5	66	51.5	41.3																30
32		94.5	94.5	105	103	101	102	91	74	64.5	51.6	41.5	40															32
34				98	96.5	95.5	97	88.5	71	62.5	51.6	41.8	39.6	32.7														34
36				91.5	90	89	92.5	85.5	68	60	51.6	42.2	38.8	32.7														36
38				86	84.5	85	87.5	83	65	58	50.5	42.2	38.1	32.7														38
40				80	79.5	81.5	82.5	79.5	62.5	55.9	49.3	42	37.4	32.6														40
45				63	69	71.5	71.5	70	56.3	51.2	45.5	40.3	35.4	31.3														45
50					62.5	63	62.5	61.5	51.9	47.2	42	37.7	33.6	29.9														50
55					53.2	55.9	55.3	54.1	48.1	43.7	39	35.2	31.8	28.4														55
60						49.8	49.1	48	44.4	40.3	36.3	32.8	30.2	27.1														60
65						44.7	44.1	43	41.7	37.1	33.9	30.8	28.7	25.8														65
70							36.7	39.8	38.7	39.2	34.2	31.7	28.9	24.6														70
75								35.2	34.8	36.1	31.4	29.6	27.2	23.4														75
80								30.3	32.8	32.7	29.1	27.6	25.6	22.2														80
85									30.8	29.7	27.5	25.4	24.1	20.9														85
90									28.3	27.2	25.7	23.9	22.7	19.7														90
95									24.2	24.9	23.7	22.3	21.3	18.6														95
100										22.7	22.6	21.2	20	17.6														100
105										20.5	21.4	20.1	18.9	16.5														105
110										18	19.8	18.7	17.6	15.7														110
115											18.1	17.2	16.7	14.8														115
120												16.4	15.9	14														120
125												15.7	15.2	13.3														125
130												14.6	14.1	12.5														130
135												12.1	13.1	11.9														135
140													12.1	11.1														140
145													11	10.2														145
150													8.8	9.5														150
155														8.8														155
160														7.6														160
165																												165
170																												170
175																												175

* over rear / en arrière

TAB 138129 / 138132

Remarks referring to load charts

- When calculating crane stresses and loads, German Industrial Standards (DIN) are applicable, in conformity with German legislation (published 2/85): The lifting capacities (stability margin) DIN/ISO are as laid down in DIN 15019, part 2, and ISO 4305. The crane's structural steel works is in accordance with DIN 15018, part 3. Design and construction of the crane comply with DIN 15018, part 2, and with F. E. M. regulations.
- For the DIN/ISO load charts, depending on jib length, crane operation may be permissible at wind speeds up to 5 resp. 7 Beaufort.
- Lifting capacities are given in metric tons.
- The weight of the hook blocks and hooks must be deducted from the lifting capacities.
- Working radii are measured from the slewing centreline.
- The lifting capacities given for the telescopic boom only apply if the folding jib is taken off.
- Subject to modification of lifting capacities.
- Lifting capacities above 220/276 kips only with additional pulley block/special equipment.

Lifting capacities on telescopic boom Forces de levage à la flèche télescopique

	41 ft - 184 ft		360°		72200 lbs		85%																		
	41 ft		54 ft		67 ft		80 ft		94 ft		107 ft		120 ft		133 ft		146 ft		159 ft		172 ft		184 ft		
ft	*																								
9	276	273																							
10	273	271																							
11	255	254	207																						
12	237	237	207																						
13	221	221	207	202	163																				
14	208	208	198	192	163	133																			
15	196	196	188	182	163	133																			
16	189	189	181	175	163	133	101																		
17	181	181	174	168	160	132	101																		
18	174	174	168	162	155	131	101	67																	
20	159	159	155	150	145	128	101	84																	
22	145	145	144	140	136	123	101	84	61																
24	132	132	132	130	127	117	100	83.5	66																
26	121	120	121	120	119	116	99.5	82.5	66.5	49.5															
28	112	110	111	110	109	110	96.5	80	66.5	51.4															
30	103	101	103	101	101	104	93.5	77.5	66	51.5	41.3														
32	93	92.5	95	93.5	96.5	96	89.5	74	64.5	51.6	41.5	40													
34			88	86.5	90.5	88.5	84	71	62.5	51.6	41.8	39.6	32.7												
36			82.5	82.5	84	82	77.5	68	60	51.6	42.2	38.8	32.7												
38			77.5	78	79	76.5	72.5	65	58	50.5	42.2	38.1	32.7												
40			72.5	74	74	71.5	67.5	62	55.9	49.3	42	37.4	32.6												
45			62	63.5	63.5	61	57.7	55	51.2	45.5	40.3	35.4	31.3												
50				54.8	54.9	53	50	49.2	45.4	42	37.7	33.6	29.9												
55				47.7	47.9	46.4	44.7	44.2	41	38.5	35.2	31.8	28.4												
60					42	41	41.3	39.1	36.7	34.7	32.8	30.2	27.1												
65						37.3	36.5	37.1	34.9	32.6	30.6	28.7	25.8												
70							33.4	32.6	33.5	31.4	30.5	29.4	27.2	24.6											
75								29.3	30.3	28.4	28.2	26.5	25.7	23.4											
80								26.5	27.5	25.7	25.6	24.1	24.2	22.1											
85								23.9	24.9	24.3	23.3	22.7	22.1	20.4											
90									22.6	22.7	21.4	21	20.2	18.7											
95									20.6	20.9	19.5	19.3	18.5	17											
100										19.1	18.3	17.8	16.9	15.4											
105										17.6	17.3	16.2	15.4	14.1											
110										16.2	15.9	14.8	14	12.9											
115											14.7	13.6	12.8	11.7											
120												13.6	12.4	11.6											
125													12.4	11.6											
130													11.4	10.6											
135													10.5	9.7											
140													9.8	8.9											
145														8.2											
150														7.6											
155														6.9											
160															5.1										
165															4.5										
170																4									
175																	3.4								
																		3							

* over rear / en arrière

TAB 138130 / 138133

Remarques relatives aux tableaux des charges

1. La grue est calculée selon normes DIN conformément au décret fédéral 2/85. Les charges DIN/ISO respectent les sécurités au basculement requises par les normes DIN 15019, partie 2 et ISO 4305. La structure de la grue est conçue selon la norme DIN 15018, partie 3. La conception générale est réalisée selon la norme DIN 15018, partie 2, ainsi que selon les recommandations de la F. E. M.
2. Les charges DIN/ISO tiennent compte d'efforts au vent selon Beaufort de 5 à 7 en fonction de la longueur de flèche.
3. Les charges sont indiquées en tonnes.
4. Les poids du crochet ou de la moufle sont à déduire des charges indiquées.
5. Les portées sont prises à partir de l'axe de rotation de la partie tournante.
6. Les charges données en configuration flèche télescopiques s'entendent sans la fléchette pliante repliée contre le télescope en position route ou en position de travail en tête de télescope.
7. Charges données sous réserve de modification.
8. Forces de levage plus de 220/276 kips seulement avec moufle additional/équipement supplémentaire.

Lifting heights Hauteurs de levage

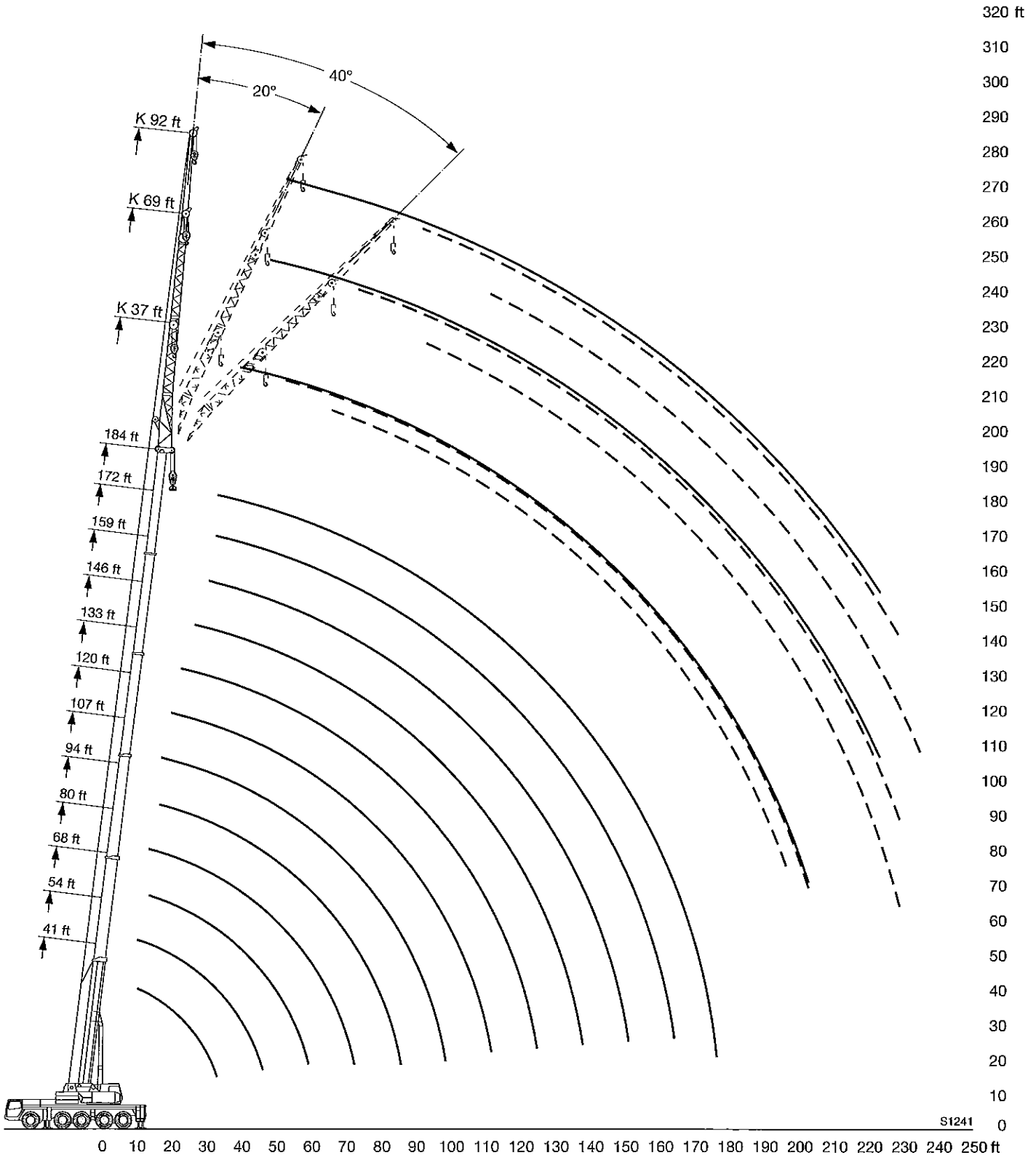

S1241

0 10 20 30 40 50 60 70 80 90 100 110 120 130 140 150 160 170 180 190 200 210 220 230 240 250 ft

Lifting capacities on the folding jib

Forces de levage à la fléchette pliante

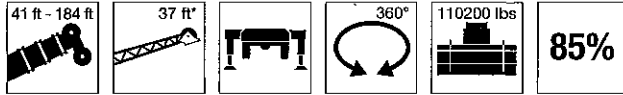

ft	41 ft			133 ft			146 ft			159 ft			172 ft			184 ft			ft
	0°	20°	40°	0°	20°	40°	0°	20°	40°	0°	20°	40°	0°	20°	40°	0°	20°	40°	
11	34.6																		11
12	34.6																		12
13	34.6																		13
14	34.6																		14
15	34.6																		15
16	34.6																		16
17	34.2																		17
18	33.6	29.8																	18
20	32.2	29.7																	20
22	30.6	28.8																	22
24	29	27.8																	24
26	27.5	26.6		34.6															26
28	26.2	25.7	19.9	34.6			34												28
30	24.9	24.8	19.8	34.6			34												30
32	23.6	24	19.7	34.6			34		28.4										32
34	22.3	23.2	19.3	34.6			34		28.4										34
36	21	22.5	18.9	34.6			34		28.4				23						36
38	19.8	21.8	18.6	34.6	29.8		34		28.4				23			17.4			38
40	18.8	20.9	18.2	34.6	29.7		33.8		28.3				23			17.4			40
45	16.7	18.5	17.6	34.2	28.4		32.4	27.9	27.3	25.5			22.4			17.4			45
50	14.9	16.3	16.9	32.6	27.1	19.9	31.1	27	19.9	26	24.6		21.7	19.2		17.4	17		50
55	13.2	14.4	15.5	30.7	26	19.7	29.6	25.9	19.7	24.7	23.6	17.4	20.8	18.8		17.3	16.7		55
60	11.7	12.7	13.5	28.9	24.9	19.3	28.1	25	19.3	23.5	22.5	17.4	19.8	18		16.9	16.1		60
65	10.6	11.3	11.8	27.3	24	18.9	26.6	24.1	18.9	22.4	21.4	17.4	18.8	17.3	16.5	16.2	15.5	15	65
70				25.8	23.2	18.5	25.1	23.3	18.5	21.3	20.4	17.4	18	16.6	16	15.5	15	14.5	70
75				24.3	22.4	18.1	23.6	22.6	18.2	20.3	19.4	17.4	17.2	15.9	15.4	14.9	14.4	14	75
80				22.7	21.6	17.8	22.2	21.8	17.9	19.3	18.5	17.3	16.4	15.3	14.9	14.2	13.8	13.5	80
85				21.2	20.8	17.6	20.9	20.8	17.7	18.4	17.7	17	15.6	14.7	14.3	13.6	13.3	13	85
90				19.9	19.6	17.4	19.7	19.9	17.5	17.6	16.9	16.4	14.9	14.1	13.8	13	12.7	12.5	90
95				18.7	18.5	17.2	18.5	18.8	17.3	16.7	16.2	15.7	14.2	13.6	13.3	12.5	12.2	12.1	95
100				17.7	17.5	16.9	17.4	17.7	17.1	15.9	15.5	15.1	13.6	13	12.8	11.9	11.7	11.7	100
105				16.8	16.5	16.6	16.3	16.7	16.9	15	14.8	14.5	13	12.5	12.4	11.4	11.2	11.2	105
110				15.9	15.7	15.7	15.3	15.7	16.1	14.1	14.2	13.9	12.4	12	12	11	10.8	10.8	110
115				15.1	14.9	14.9	14.5	14.8	15.2	13.3	13.5	13.4	11.8	11.5	11.5	10.6	10.4	10.4	115
120				14.3	14.1	14.2	13.7	14	14.3	12.7	12.9	12.9	11.3	11	11.1	10.2	10	10.1	120
125				13.5	13.4	13.5	12.8	13.3	13.5	12.1	12.2	12.3	10.8	10.6	10.7	9.8	9.6	9.7	125
130				12.8	12.7	12.9	11.7	12.3	12.6	11.5	11.6	11.9	10.5	10.2	10.4	9.4	9.3	9.3	130
135				11.8	12.1	12.3	11	11.3	11.6	10.7	11.1	11.3	10	9.9	10	9	9	9.1	135
140				10.8	11.3	11.5	10.4	10.4	10.6	9.9	10.4	10.6	9.6	9.6	9.7	8.6	8.7	8.8	140
145				10	10.4	10.5	9.9	9.9	10.1	9.3	9.6	9.9	9.1	9.2	9.4	8.2	8.4	8.5	145
150				9.3	9.6	9.6	9.3	9.4	9.7	8.8	8.9	9.2	8.7	8.9	9.1	7.8	8.1	8.3	150
155				8.7	8.9		8.7	9	9.1	8.4	8.5	8.6	8.1	8.5	8.7	7.5	7.7	7.9	155
160							8.2	8.4	8.5	8	8.1	8.2	7.5	7.9	8.2	7.1	7.3	7.5	160
165							7.6	7.8		7.7	7.7	7.9	7	7.4	7.6	6.8	7	7.2	165
170							7.1	7.3		7.3	7.5	7.6	6.5	6.8	7	6.4	6.7	6.8	170
175										6.9	7	7.1	6	6.3	6.4	6	6.3	6.4	175
180										6.4	6.6		5.5	5.8	5.9	5.5	5.8	6	180
185													5	5.3	5.4	5	5.4	5.5	185
190													4.5	4.8	4.8	4.5	4.8	4.9	190
195																4	4.3	4.3	195
200																3.5	3.8		200

* one-parted folding jib / fléchette pliante à 1 élément

TAB 138135 / 138136 / 138141

Lifting capacities on the folding jib

Forces de levage à la fléchette pliante

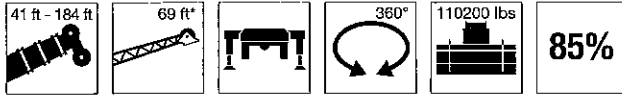

ft	41 ft			133 ft			146 ft			159 ft			172 ft			184 ft			ft		
	69 ft			69 ft			69 ft			69 ft			69 ft			69 ft					
	0°	20°	40°	0°	20°	40°	0°	20°	40°	0°	20°	40°	0°	20°	40°	0°	20°	40°			
13																					
14	17																				17
15	17																				17
16	16.9																				16.9
17	16.8																				16.8
18	16.7																				16.7
20	16.6																				16.6
22	16.4																				16.4
24	16.2																				16.2
26	16																				16
28	15.9																				15.9
30	15.7				17																15.7
32	15.6				17																15.6
34	15.4	13.8			17			15.8													15.4
36	15.2	13.8			16.9			15.8													15.2
38	14.9	13.8			16.8			15.8		14.3											14.9
40	14.7	13.8			16.7			15.8		14.3			12.4								14.7
45	14.5	13.7			16.5			15.7		14.3			12.4								14.5
45	13.9	13.1			16.3			15.5		14.3			12.4						10.7		13.9
50	13.4	12.5	10.7		16			15.3		14.1			12.3						10.7		13.4
55	12.8	12	10.5	15.8	13.8			15.1	13.6	14			12.3						10.7		12.8
60	12	11.5	10.1	15.6	13.8			14.9	13.5	13.7			12.2						10.7		12
65	11.1	11	9.6	15.4	13.5			14.7	13.2	13.6	12.5		12.1						10.6		11.1
70	10.2	10.6	9.2	15.1	13.2			14.5	12.9	13.4	12.2		11.7	10.8					10.4	9.7	10.2
75	9.5	10.1	8.9	14.8	12.9	10.2		14.3	12.6	9.9	13.2	12	11.3	10.6					10.2	9.6	9.5
80	8.8	9.6	8.7	14.4	12.6	10.2	14	12.3	9.9	13	11.8		10.9	10.3					9.9	9.5	8.8
85	8.2	9.1	8.5	14.1	12.3	10		13.7	12.1	9.9	12.9	11.5	9.5	10.5	10				9.6	9.2	8.2
90	7.7	8.4	8.3	13.8	12	9.8		13.5	11.8	9.7	12.5	11.3	9.4	10.2	9.7	9			9.4	8.9	7.7
95	7	7.7	7.8	13.6	11.7	9.6		13.2	11.6	9.5	12	11.1	9.3	9.9	9.4	8.9			9.1	8.7	7
100				13.3	11.5	9.4		13	11.4	9.3	11.5	10.8	9.1	9.6	9.2	8.7			8.8	8.4	
105				13	11.2	9.2		12.7	11.2	9.2	11.1	10.5	9	9.3	8.9	8.5			8.5	8.2	
110				12.6	11	9.1		12.5	11	9.1	10.7	10.2	8.9	9	8.6	8.3			8.3	8	
115				12.1	10.8	9		12.1	10.8	8.9	10.3	9.9	8.8	8.7	8.4	8.2			8	7.7	
120				11.6	10.6	8.8		11.6	10.6	8.8	9.9	9.6	8.6	8.5	8.1	8			7.8	7.5	
125				11.2	10.4	8.7		11.2	10.4	8.7	9.6	9.3	8.5	8.2	7.9	7.8			7.5	7.3	
130				10.7	10.1	8.6		10.6	10.2	8.6	9.2	9	8.4	8	7.7	7.6			7.3	7.1	
135				10.2	9.9	8.6		10.1	10	8.5	8.9	8.8	8.4	7.7	7.5	7.4			7	6.9	
140				9.7	9.6	8.5		9.6	9.8	8.5	8.6	8.5	8.3	7.5	7.3	7.3			6.8	6.7	
145				9.4	9.4	8.4		9.2	9.6	8.4	8.3	8.3	8.3	7.3	7.1	7.1			6.6	6.6	
150				9	9.1	8.4		8.8	9.3	8.4	8.1	8.1	8.1	7	6.9	6.9			6.4	6.4	
155				8.7	8.8	8.4		8.4	8.9	8.3	7.8	7.8	7.9	6.8	6.8	6.8			6.2	6.2	
160				8.3	8.4	8.4		7.8	8.5	8.3	7.5	7.6	7.7	6.6	6.6	6.7			6	6	
165				8	8.1	8.2		7.3	8	8.3	7.2	7.4	7.5	6.4	6.5	6.5			5.8	5.9	
170				7.6	7.8	8		6.9	7.4	7.8	6.8	7.2	7.3	6.2	6.3	6.4			5.6	5.7	
175				7.2	7.5	7.7		6.7	6.9	7.2	6.3	6.9	7.1	6.1	6.1	6.3			5.4	5.5	
180				6.7	7.1			6.4	6.5	6.7	5.8	6.4	6.8	5.8	5.9	6.1			5.2	5.4	
185				6.3	6.6			6.1	6.3	6.4	5.6	6	6.3	5.6	5.8	6			5	5.2	
190				5.9	6.1			5.8	6.1	6.1	5.4	5.5	5.7	5.1	5.6	5.8			4.7	5.1	
195								5.5	5.7		5.2	5.4	5.5	4.7	5.3	5.5			4.4	4.8	
200								5.1	5.3		5	5.2	5.3	4.2	4.8	5.1			4	4.6	
205											4.8	5		3.8	4.4	4.6			3.5	4.2	
210														3.3	3.9	4			3.1	3.8	
215														2.9	3.4	3.4			2.7	3.3	
220														2.6	2.9				2.3	2.8	
225																			2.4	2.5	

* bi-parted folding jib / fléchette pliante à 2 éléments

TAB 138135 / 138138 / 138141

Lifting capacities on the folding jib

Forces de levage à la fléchette pliante

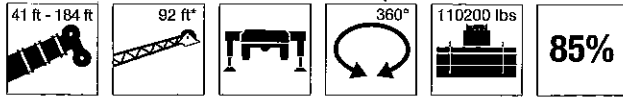

ft	41 ft 92 ft			133 ft 92 ft			146 ft 92 ft			159 ft 92 ft			172 ft 92 ft			184 ft 92 ft			ft
	0°	20°	40°	0°	20°	40°	0°	20°	40°	0°	20°	40°	0°	20°	40°	0°	20°	40°	
18	12.1																		18
20	12.1																		20
22	12																		22
24	12																		24
26	12																		26
28	11.9																		28
30	11.8																		30
32	11.6			12.1															32
34	11.5			12.1															34
36	11.3			12.1															36
38	11.2			12.1			11.2												38
40	11			12.1			11.2												40
45	10.5	9.7		12			11.2			9.9									45
50	10.1	9.5		11.9			11.1			9.9			8.8			7.8			50
55	9.6	9.2		11.8			11			9.9			8.7			7.8			55
60	9.2	8.7		11.6			10.9			9.9			8.7			7.8			60
65	8.7	8.3		11.4			10.8			9.8			8.7			7.8			65
70	8.4	8	6.6	11.2	9.5		10.7	9.3		9.7			8.6			7.8			70
75	8	7.6	6.4	10.9	9.4		10.5	9.1		9.6			8.5			7.7			75
80	7.7	7.3	6.2	10.6	9.1		10.3	8.9		9.4	8.5		8.4			7.7			80
85	7.4	7	6	10.4	8.9		10.1	8.7		9.3	8.3		8.2	7.5		7.5			85
90	7.1	6.7	5.8	10.1	8.7	6.6	9.8	8.5		9.1	8.1		8	7.4		7.3	6.8		90
95	6.8	6.5	5.6	9.8	8.4	6.5	9.6	8.3	6.4	9	7.9		7.8	7.2		7.1	6.7		95
100	6.5	6.4	5.4	9.5	8.2	6.4	9.4	8.1	6.3	8.8	7.7	5.8	7.5	7		6.9	6.5		100
105	6.1	6.2	5.3	9.3	8	6.3	9.1	7.9	6.2	8.6	7.6	5.8	7.3	6.8		6.7	6.4		105
110	5.7	6.1	5.2	9	7.8	6.1	8.9	7.7	6.1	8.4	7.4	5.8	7.1	6.6	5.6	6.5	6.2	5.3	110
115	5.4	5.9	5.2	8.8	7.6	6	8.7	7.6	6	8.2	7.3	5.8	6.9	6.5	5.6	6.3	6.1	5.3	115
120	5	5.5		8.5	7.4	5.9	8.4	7.4	5.8	8	7.1	5.7	6.7	6.3	5.5	6.1	5.9	5.3	120
125				8.3	7.3	5.8	8.2	7.2	5.8	7.8	7	5.6	6.5	6.1	5.4	5.9	5.8	5.3	125
130				8.1	7.1	5.7	8	7.1	5.7	7.6	6.9	5.6	6.3	6	5.4	5.8	5.6	5.2	130
135				7.9	7	5.6	7.8	6.9	5.6	7.3	6.8	5.5	6.1	5.8	5.3	5.6	5.4	5.2	135
140				7.7	6.8	5.5	7.7	6.8	5.5	7.1	6.6	5.4	6	5.7	5.2	5.4	5.3	5.1	140
145				7.5	6.7	5.5	7.5	6.7	5.4	6.9	6.5	5.4	5.8	5.6	5.2	5.3	5.1	5	145
150				7.4	6.6	5.4	7.4	6.6	5.4	6.6	6.4	5.3	5.6	5.4	5.1	5.1	5	5	150
155				7.2	6.5	5.3	7.2	6.4	5.3	6.4	6.3	5.3	5.4	5.3	5.1	5	4.9	4.9	155
160				7	6.4	5.3	7.1	6.4	5.3	6.2	6.1	5.2	5.3	5.2	5.1	4.8	4.7	4.8	160
165				6.9	6.3	5.2	6.9	6.3	5.3	6.1	6	5.2	5.1	5	5	4.7	4.6	4.7	165
170				6.7	6.2	5.2	6.7	6.2	5.2	5.9	5.9	5.2	5	4.9	4.9	4.5	4.5	4.6	170
175				6.5	6.1	5.2	6.3	6.1	5.2	5.7	5.7	5.1	4.9	4.7	4.8	4.4	4.3	4.4	175
180				6.2	6.1	5.2	5.9	6.1	5.2	5.5	5.6	5.1	4.7	4.6	4.7	4.2	4.2	4.3	180
185				6	6	5.2	5.4	6	5.2	5.3	5.4	5.1	4.6	4.5	4.6	4.1	4.1	4.2	185
190				5.8	5.9	5.2	5.1	5.7	5.2	5	5.3	5.1	4.4	4.4	4.5	3.9	4	4.1	190
195				5.5	5.7	5.2	5	5.3	5.2	4.5	5.1	5.1	4.3	4.3	4.4	3.8	3.9	4	195
200				5.1	5.5		4.8	4.9	5	4.1	4.9	5.1	4.1	4.2	4.3	3.7	3.8	4	200
205				4.8	5.2		4.5	4.7	4.8	4	4.5	4.9	3.8	4.1	4.3	3.5	3.7	3.8	205
210							4.2	4.5		3.8	4	4.4	3.3	4	4.2	3.1	3.6	3.7	210
215							3.8	4.3		3.7	3.8	3.9	2.9	3.7	4.1	2.6	3.4	3.6	215
220							3.5	3.3		3.5	3.7	3.8	2.5	3.3	3.7	2.3	3.1	3.5	220
225										3.2	3.5		2.2	2.9	3.2		2.7	3.2	225
230										2.8				2.4	2.7		2.3	2.7	230
235										2.5				2	2.2		1.9	2.2	235

* three-parted folding jib / fléchette pliante à 3 éléments

Lifting capacities on the folding jib with boom extension

Forces de levage à la fléchette pliante avec télescope rallongé

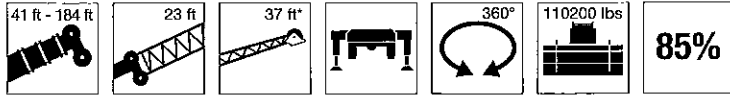

m	41 ft + 23 ft			146 ft + 23 ft			159 ft + 23 ft			172 ft + 23 ft			184 ft + 23 ft			m
	37 ft			37 ft			37 ft			37 ft			37 ft			
	0°	20°	40°	0°	20°	40°	0°	20°	40°	0°	20°	40°	0°	20°	40°	
13	17.4															13
14	17.4															14
15	17.4															15
16	17.4															16
17	17.4															17
18	17.3															18
20	17.1															20
22	16.3	15.3														22
24	15.7	15.3														24
26	15	15.3														26
28	14.4	15														28
30	13.8	14.7														30
32	13.3	14.1	13.7													32
34	12.7	13.6	13.6													34
36	12.2	13.1	13.5	17.4												36
38	11.7	12.5	13.1	17.4			17									38
40	11.2	12.1	12.6	17.4			16.9									40
45	10.2	10.9	11.5	17.3			16.4			15			12.6			45
50	9.4	9.9	10.6	16.6	15.3		15.7	14.8		14.7			12.5			50
55	8.6	9.1	9.7	15.8	14.9	13.7	15.2	14.5		14.2	13.3		12.3	11.6		55
60	7.9	8.4	8.8	15	14.2	13.5	14.6	13.8		13.7	13.2		12	11.6		60
65	7.3	7.8	8.2	14.2	13.6	13	13.9	13.3	12.6	13.2	12.7	12.2	11.6	11.2		65
70	6.8	7.2	7.6	13.5	13	12.4	13.2	12.7	12.2	12.6	12.1	11.8	11.2	10.9	10.4	70
75	6.3	6.7	7	12.8	12.4	11.9	12.6	12.1	11.7	12.1	11.7	11.4	10.8	10.5	10.3	75
80	5.8	6.1	6.4	12.2	11.8	11.4	12	11.6	11.3	11.6	11.2	11	10.4	10.1	10	80
85	5.2	5.6	5.9	11.6	11.3	11	11.5	11.1	10.9	11.1	10.8	10.6	10	9.7	9.7	85
90	4.7	5		11	10.8	10.6	11	10.7	10.5	10.7	10.4	10.2	9.7	9.4	9.3	90
95				10.5	10.3	10.2	10.5	10.3	10.1	10.2	10	9.9	9.3	9.1	9	95
100				10	9.8	9.8	10.1	9.8	9.7	9.9	9.6	9.5	9	8.8	8.7	100
105				9.6	9.4	9.4	9.7	9.5	9.4	9.5	9.3	9.2	8.7	8.5	8.5	105
110				9.2	9	9	9.4	9.1	9	9.2	9	9	8.4	8.2	8.2	110
115				8.9	8.7	8.7	9.1	8.8	8.7	8.9	8.7	8.7	8.1	8	8	115
120				8.6	8.4	8.4	8.7	8.5	8.5	8.6	8.4	8.4	7.9	7.7	7.7	120
125				8.2	8.1	8.1	8.4	8.2	8.2	8.3	8.2	8.2	7.6	7.5	7.5	125
130				7.9	7.8	7.8	8.1	8	8	8.1	7.9	7.9	7.3	7.3	7.3	130
135				7.5	7.6	7.6	7.8	7.7	7.7	7.8	7.7	7.7	7	7.1	7.1	135
140				7.2	7.3	7.3	7.5	7.5	7.5	7.5	7.5	7.5	6.8	6.8	6.9	140
145				7	7	7.1	7.2	7.2	7.3	7.3	7.3	7.3	6.6	6.6	6.7	145
150				6.8	6.8	6.9	6.9	7	7	7	7.1	7.1	6.4	6.4	6.5	150
155				6.5	6.5	6.6	6.7	6.7	6.8	6.8	6.8	6.8	6.9	6.2	6.3	155
160				6.3	6.3	6.4	6.5	6.5	6.6	6.6	6.6	6.6	6.7	6	6.1	160
165				6	6.1	6.2	6.3	6.3	6.4	6.4	6.4	6.5	5.8	5.8	5.9	165
170				5.8	5.9	5.9	6.1	6.1	6.2	6.2	6.2	6.3	5.5	5.6	5.7	170
175				5.5	5.6	5.6	5.9	5.9	6	5.9	6	6.1	5.3	5.4	5.5	175
180				5.2	5.3	5.3	5.7	5.7	5.8	5.6	5.8	5.9	5	5.2	5.3	180
185				5	5.1		5.5	5.6	5.6	5.1	5.4	5.6	4.8	5	5.1	185
190				4.7	4.8		5.3	5.4	5.4	4.6	5	5.1	4.4	4.7	4.8	190
195							5	5.1	5.2	4.1	4.4	4.6	3.9	4.3	4.4	195
200							4.7	4.8		3.6	3.9	4	3.4	3.8	3.9	200
205										3.2	3.4	3.5	2.9	3.3	3.4	205
210										2.7	3		2.5	2.8	2.9	210
215										2.3	2.5		2.1	2.4	2.4	215
220													2	2	2	220

* one-parted folding jib / fléchette pliante à 1 élément

TAB 138144 / 138147 / 138150

Lifting heights Hauteurs de levage

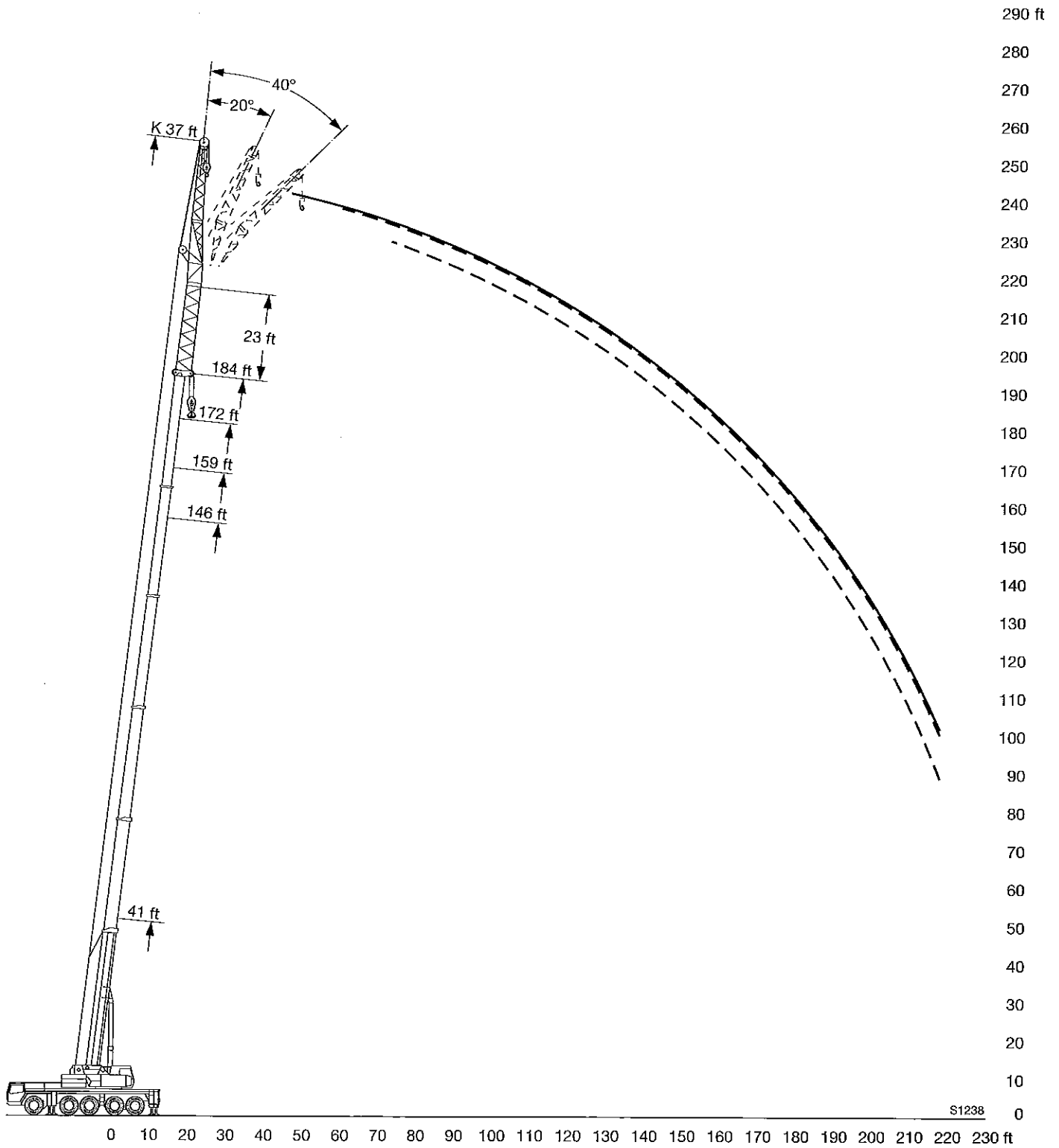

Lifting capacities on the folding jib with boom extension

Forces de levage à la fléchette pliante avec télescope rallongé



m	41 ft + 23 ft			146 ft + 23 ft			159 ft + 23 ft			172 ft + 23 ft			184 ft + 23 ft			m
	60 ft			60 ft			60 ft			60 ft			60 ft			
	0°	20°	40°	0°	20°	40°	0°	20°	40°	0°	20°	40°	0°	20°	40°	
18	12.1															18
20	12.1															20
22	12.1															22
24	12.1															24
26	12															26
28	11.7															28
30	11.4															30
32	11															32
34	10.7															34
36	10.4	10														36
38	10	10		12.1												38
40	9.7	9.9		12.1												40
45	8.9	9.3		12.1												45
50	8.3	8.7	8.6	12.1			11.4			10.4			9			50
55	7.7	8.2	8.4	11.9			11.3			10.4			9			55
60	7.1	7.6	8	11.5			11			10.2			8.9			60
65	6.6	7.1	7.4	11	10		10.7	9.7		10			8.8			65
70	6.2	6.7	7	10.6	9.7		10.2	9.5		9.7	9		8.6	8.3		70
75	5.8	6.2	6.6	10.1	9.3	8.6	9.8	9.1		9.4	8.8		8.4	8.1		75
80	5.4	5.8	6.2	9.6	8.9	8.5	9.4	8.8		9.1	8.5		8.1	7.9		80
85	5.1	5.4	5.8	9.2	8.6	8.3	9.1	8.5	8.1	8.7	8.3	7.8	7.9	7.6		85
90	4.7	5.1	5.4	8.9	8.3	8	8.7	8.2	7.9	8.4	8	7.7	7.7	7.4	7.1	90
95	4.3	4.7	5.1	8.5	8	7.7	8.4	8	7.6	8.2	7.8	7.5	7.4	7.2	7	95
100	4	4.4	4.7	8.1	7.8	7.5	8.1	7.7	7.4	7.9	7.5	7.3	7.2	7	6.8	100
105	3.7	4.1		7.8	7.5	7.2	7.8	7.5	7.2	7.6	7.3	7.1	6.9	6.8	6.6	105
110	3.4	3.7		7.5	7.2	7	7.5	7.2	7	7.4	7.1	6.9	6.7	6.5	6.4	110
115				7.2	7	6.8	7.2	7	6.8	7.1	6.9	6.7	6.5	6.3	6.3	115
120				6.9	6.8	6.6	7	6.8	6.6	6.9	6.7	6.5	6.2	6.1	6.1	120
125				6.7	6.5	6.4	6.7	6.6	6.4	6.6	6.5	6.3	6	5.9	6	125
130				6.4	6.3	6.2	6.4	6.3	6.2	6.4	6.3	6.2	5.8	5.8	5.8	130
135				6.1	6.1	6.1	6.2	6.1	6.1	6.2	6.1	6	5.7	5.6	5.6	135
140				5.9	5.9	5.9	6	5.9	5.9	6	5.9	5.9	5.5	5.4	5.4	140
145				5.7	5.6	5.7	5.8	5.7	5.8	5.8	5.7	5.7	5.3	5.3	5.3	145
150				5.5	5.5	5.5	5.6	5.6	5.6	5.6	5.5	5.6	5.1	5.1	5.1	150
155				5.3	5.3	5.3	5.4	5.4	5.4	5.5	5.4	5.4	5	4.9	5	155
160				5.2	5.1	5.2	5.3	5.2	5.3	5.3	5.2	5.3	4.8	4.8	4.8	160
165				5	4.9	5	5.1	5	5.1	5.1	5.1	5.1	4.6	4.6	4.7	165
170				4.7	4.8	4.9	4.9	4.9	5	5	4.9	5	4.5	4.5	4.6	170
175				4.6	4.6	4.7	4.7	4.7	4.8	4.8	4.8	4.9	4.3	4.4	4.5	175
180				4.4	4.5	4.6	4.6	4.6	4.7	4.7	4.7	4.8	4.2	4.2	4.3	180
185				4.2	4.3	4.5	4.4	4.5	4.6	4.5	4.6	4.6	4	4.1	4.2	185
190				4	4.1	4.3	4.3	4.3	4.5	4.4	4.4	4.5	3.9	4	4.1	190
195				3.9	4	4.1	4.1	4.2	4.3	4.1	4.3	4.4	3.7	3.8	3.9	195
200				3.7	3.8	3.9	4	4	4.2	3.7	4.1	4.3	3.4	3.7	3.8	200
205				3.5	3.6		3.8	3.9	4	3.2	3.8	4	3	3.5	3.7	205
210							3.7	3.8	3.9	2.8	3.4	3.6	2.5	3.2	3.5	210
215							3.4	3.7	3.7	2.4	2.9	3.1	2.1	2.7	3	215
220							3	3.3		2	2.5	2.6		2.3	2.5	220

* bi-parted folding jib / fléchette pliante à 2 éléments

Lifting heights Hauteurs de levage

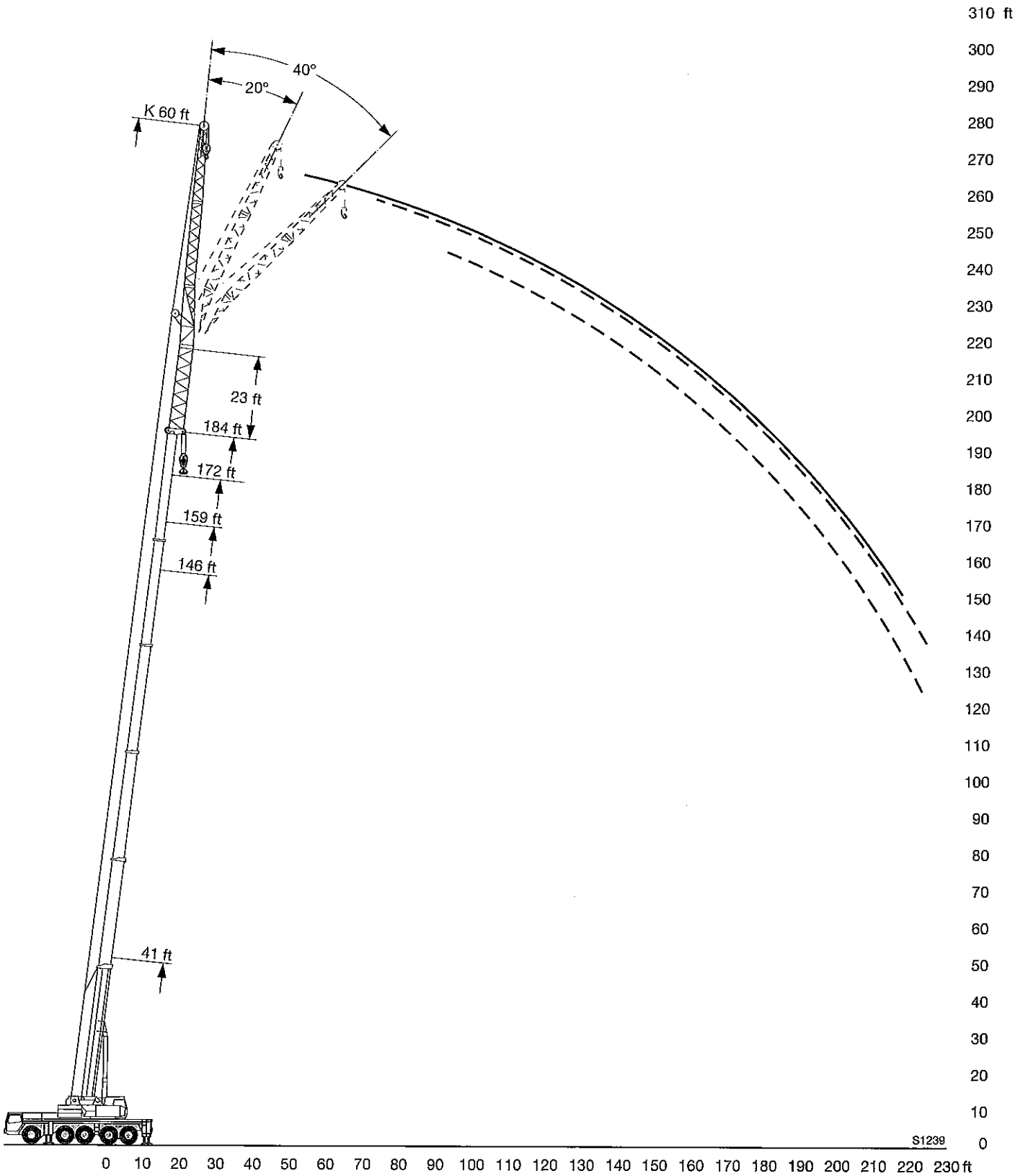

Lifting capacities on the folding jib with boom extension

Forces de levage à la fléchette pliante avec télescope rallongé



m	41 ft + 23 ft			146 ft + 23 ft			159 ft + 23 ft			172 ft + 23 ft			184 ft + 23 ft			m
	69 ft			69 ft			69 ft			69 ft			69 ft			
	0°	20°	40°	0°	20°	40°	0°	20°	40°	0°	20°	40°	0°	20°	40°	
22	10.2															22
24	10.2															24
26	10.2															26
28	10.1															28
30	10															30
32	9.8															32
34	9.7															34
36	9.5															36
38	9.2	8.7														38
40	9	8.7														40
45	8.4	8.7		10.2			9.7									45
50	7.9	8.3		10.2			9.7									50
55	7.4	7.8	7.5	10.1			9.6			9			8			55
60	6.9	7.3	7.5	10			9.5			8.9			8			60
65	6.4	6.9	7.3	9.8			9.4			8.8			7.9			65
70	6	6.5	6.9	9.5	8.7		9.2	8.3		8.6			7.9			70
75	5.6	6.1	6.5	9.1	8.6		8.9	8.2		8.4	7.8		7.7	7.3		75
80	5.3	5.8	6.1	8.8	8.3		8.6	8.1		8.2	7.7		7.5	7.2		80
85	4.9	5.4	5.7	8.5	8	7.5	8.3	7.8		8	7.6		7.3	7		85
90	4.7	5.1	5.4	8.2	7.7	7.4	8.1	7.6	7.2	7.8	7.4		7.1	6.8		90
95	4.4	4.8	5.1	7.9	7.5	7.2	7.8	7.4	7.1	7.6	7.2	6.8	6.9	6.7	6.4	95
100	4.1	4.5	4.8	7.6	7.2	7	7.6	7.1	6.9	7.4	7	6.7	6.7	6.5	6.3	100
105	3.8	4.2	4.5	7.3	7	6.8	7.3	6.9	6.7	7.1	6.8	6.6	6.4	6.3	6.1	105
110	3.6	3.9	4.2	7.1	6.8	6.5	7	6.7	6.5	6.9	6.6	6.4	6.2	6.1	6	110
115	3.3	3.6	3.7	6.8	6.5	6.3	6.8	6.5	6.3	6.6	6.4	6.2	6	6	5.8	115
120	3	3.3		6.5	6.3	6.2	6.5	6.3	6.1	6.4	6.2	6	5.8	5.8	5.7	120
125				6.3	6.1	6	6.3	6.1	6	6.2	6	5.9	5.6	5.6	5.5	125
130				6.1	5.9	5.8	6.1	5.9	5.8	6	5.9	5.8	5.5	5.4	5.4	130
135				5.8	5.8	5.7	5.9	5.8	5.7	5.8	5.7	5.6	5.3	5.3	5.3	135
140				5.6	5.6	5.5	5.7	5.6	5.5	5.7	5.5	5.5	5.2	5.1	5.1	140
145				5.4	5.4	5.4	5.5	5.5	5.4	5.5	5.4	5.3	5	5	5	145
150				5.2	5.2	5.3	5.3	5.3	5.3	5.3	5.3	5.2	4.8	4.8	4.9	150
155				5	5	5.1	5.2	5.1	5.2	5.2	5.1	5.1	4.7	4.7	4.7	155
160				4.9	4.9	5	5	4.9	5	5	5	5	4.5	4.5	4.6	160
165				4.7	4.7	4.8	4.8	4.8	4.9	4.8	4.8	4.9	4.4	4.4	4.5	165
170				4.6	4.6	4.7	4.7	4.7	4.7	4.7	4.7	4.7	4.3	4.3	4.4	170
175				4.4	4.4	4.5	4.5	4.5	4.6	4.6	4.6	4.6	4.1	4.2	4.2	175
180				4.2	4.3	4.4	4.4	4.4	4.5	4.4	4.4	4.5	4	4	4.1	180
185				4.1	4.1	4.3	4.3	4.3	4.3	4.3	4.3	4.4	3.8	3.9	4	185
190				3.9	4	4.1	4.1	4.1	4.3	4.2	4.2	4.3	3.7	3.8	3.9	190
195				3.8	3.9	4	3.9	4	4.1	4.1	4.1	4.2	3.6	3.7	3.8	195
200				3.6	3.7	3.8	3.8	3.9	4	3.8	4	4.1	3.4	3.6	3.7	200
205				3.5	3.6	3.7	3.7	3.8	3.9	3.5	3.9	4	3.2	3.4	3.6	205
210				3.3	3.4		3.5	3.6	3.8	3.1	3.8	3.9	2.8	3.3	3.4	210
215				3.2	3.3		3.4	3.5	3.6	2.7	3.4	3.6	2.4	3.1	3.3	215
220				3	3.1		3.2	3.4	3.5	2.3	2.9	3.2	2	2.7	3	220
225							3	3.2			2.5	2.7		2.3	2.6	225
230							2.6	2.9								230
235							2.3	2.5								235
240																240
245																245

* bi-parted folding jib / fléchette pliante à 2 éléments

TAB 138144 / 138147 / 138150

Lifting heights Hauteurs de levage

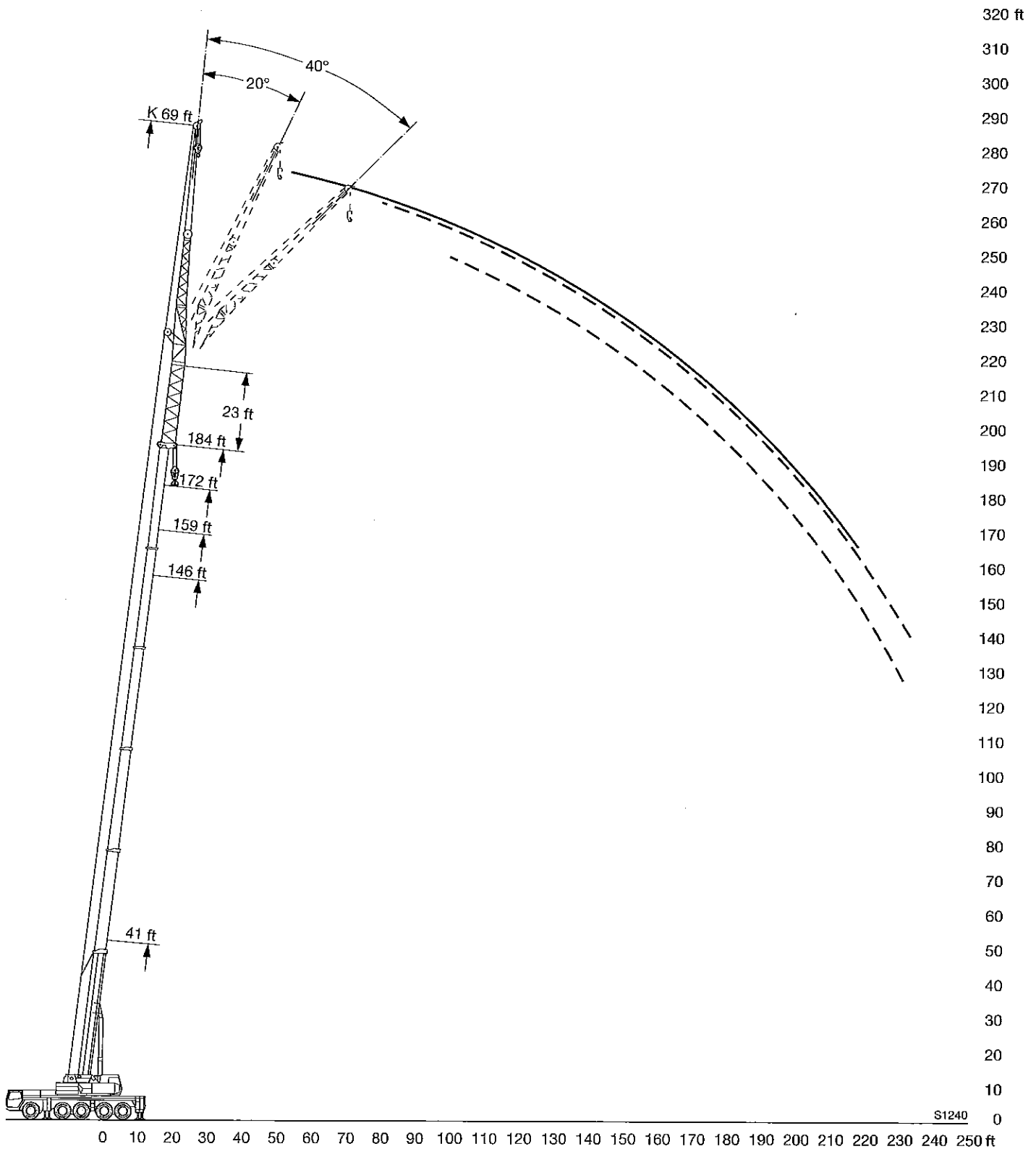

Lifting capacities on the folding jib with boom extension

Forces de levage à la fléchette pliante avec télescope rallongé

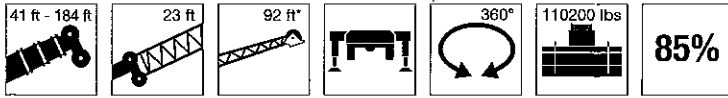

m	41 ft + 23 ft			146 ft + 23 ft			159 ft + 23 ft			172 ft + 23 ft			184 ft + 23 ft		m
	92 ft			92 ft			92 ft			92 ft			92 ft		
	0°	20°	40°	0°	20°	40°	0°	20°	40°	0°	20°	40°	0°	20°	
32	7.4														32
34	7.3														34
36	7.3														36
38	7.1														38
40	7														40
45	6.7														45
50	6.4	6		7.5			7			6.3					50
55	6.1	6		7.5			7			6.3			5.3		55
60	5.7	5.9		7.4			7			6.3			5.3		60
65	5.4	5.6		7.3			6.9			6.3			5.3		65
70	5.1	5.4		7.1			6.8			6.3			5.3		70
75	4.8	5.1	4.9	6.9			6.6			6.2			5.3		75
80	4.5	4.8	4.8	6.7			6.5			6.1			5.3		80
85	4.2	4.5	4.7	6.5	6		6.3	5.8		6			5.3		85
90	3.9	4.3	4.5	6.4	5.8		6.1	5.7		5.8	5.4		5.3	4.9	90
95	3.7	4	4.3	6.2	5.7		6	5.5		5.7	5.3		5.2	4.9	95
100	3.4	3.8	4.1	6	5.5	4.9	5.8	5.4		5.6	5.1		5.1	4.8	100
105	3.2	3.6	3.9	5.8	5.3	4.9	5.7	5.3		5.5	5		5	4.7	105
110	3	3.4	3.6	5.6	5.2	4.8	5.5	5.1	4.7	5.4	4.9		4.9	4.6	110
115	2.8	3.2	3.4	5.4	5	4.7	5.3	5	4.6	5.2	4.8	4.4	4.7	4.5	115
120	2.7	3	3.3	5.2	4.9	4.6	5.1	4.8	4.5	5	4.7	4.4	4.5	4.4	120
125	2.6	2.8	3.1	5	4.7	4.5	5	4.7	4.4	4.9	4.6	4.3	4.4	4.3	125
130	2.4	2.7	2.9	4.8	4.6	4.4	4.8	4.5	4.3	4.7	4.4	4.2	4.2	4.1	130
135	2.3	2.5	2.6	4.6	4.4	4.3	4.6	4.4	4.3	4.6	4.3	4.1	4.1	4	135
140	2.2	2.3		4.4	4.2	4.2	4.5	4.2	4.1	4.4	4.2	4.1	4	3.9	140
145				4.3	4.1	4	4.3	4.1	4	4.3	4.1	4	3.8	3.8	145
150				4.1	4	3.9	4.1	4	3.9	4.1	3.9	3.9	3.7	3.6	150
155				3.9	3.8	3.8	4	3.8	3.8	4	3.8	3.8	3.5	3.5	155
160				3.8	3.7	3.7	3.8	3.7	3.7	3.8	3.7	3.7	3.4	3.4	160
165				3.6	3.6	3.6	3.7	3.6	3.6	3.7	3.6	3.6	3.3	3.3	165
170				3.5	3.5	3.5	3.6	3.5	3.5	3.6	3.5	3.5	3.2	3.2	170
175				3.4	3.4	3.4	3.4	3.4	3.4	3.5	3.4	3.4	3.1	3.1	175
180				3.2	3.3	3.3	3.3	3.3	3.3	3.3	3.3	3.3	3	3	180
185				3.1	3.2	3.2	3.2	3.2	3.3	3.2	3.3	3.3	2.9	2.9	185
190				3	3.1	3.1	3.1	3.1	3.2	3.1	3.1	3.2	2.8	2.8	190
195				2.9	2.9	3	3	3	3.1	3	3	3.1	2.7	2.7	195
200				2.8	2.8	2.9	2.9	2.9	3	2.9	2.9	3	2.5	2.6	200
205				2.7	2.7	2.8	2.8	2.8	2.9	2.8	2.8	2.9	2.4	2.5	205
210				2.5	2.6	2.7	2.7	2.7	2.8	2.7	2.7	2.9	2.3	2.5	210
215				2.4	2.5	2.6	2.6	2.6	2.7	2.5	2.7	2.8	2.1	2.4	215
220				2.3	2.4	2.5	2.5	2.5	2.6	2.2	2.6	2.7		2.3	220
225				2.2	2.3	2.4	2.3	2.5	2.6		2.5	2.6		2.2	225
230				2.1	2.2	2.3	2.2	2.4	2.5		2.3	2.5			230
235				2	2.1	2.1	2.1	2.3	2.4		1.9	2.3			235
240				1.8	2			2.2	2.3						240
245								2							245

* three-parted folding jib / fléchette pliante à 3 éléments

TAB 138144 / 138147 / 138150

Lifting heights Hauteurs de levage

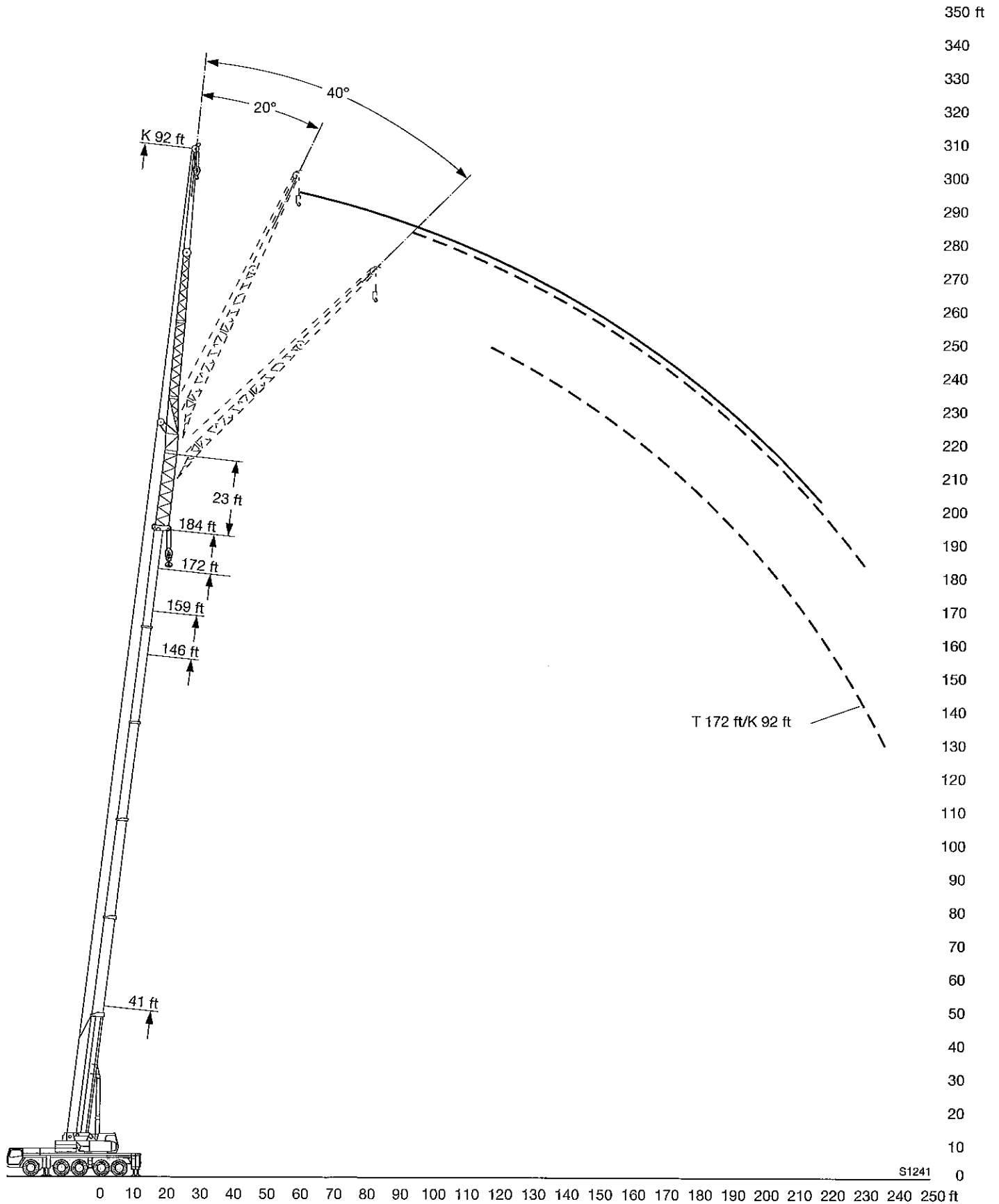

Dimensions Encombrement

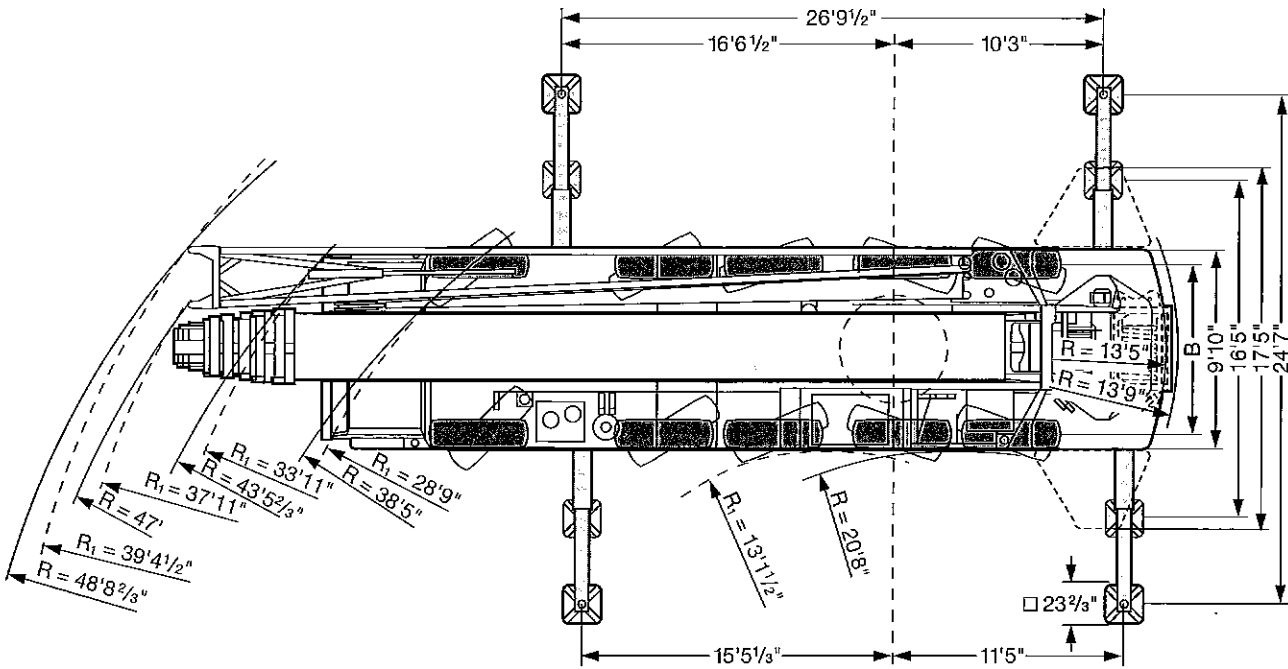
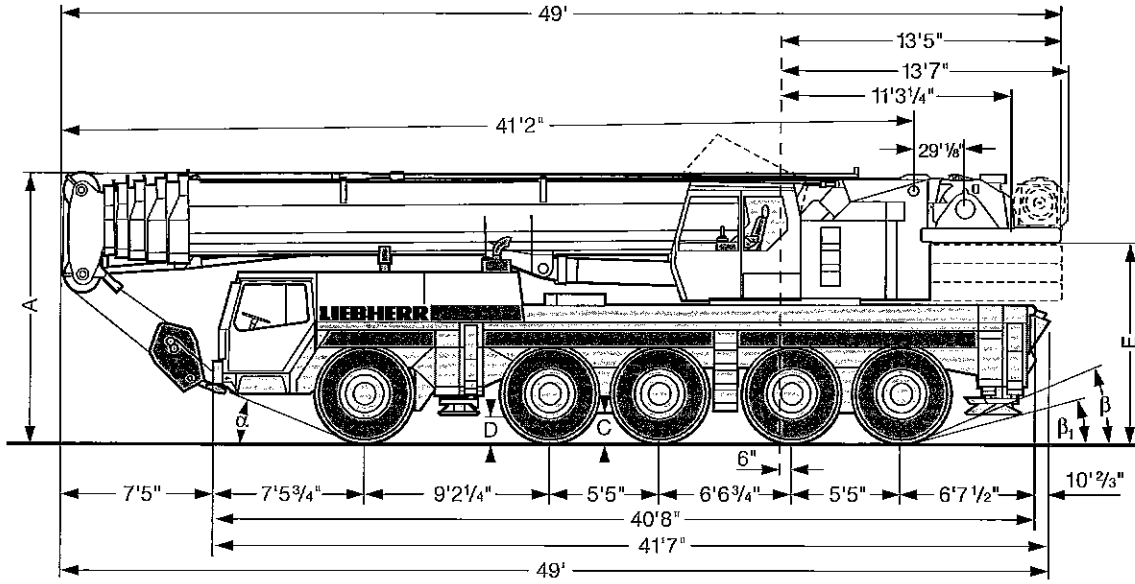

R_1 = All-wheel steering / Direction toutes roues



16.00 R 25

* lowered / abaissé

Dimensions / Encombrement mm									
A	A	B	C	D	E	α	β	β_1	
13'1 1/2"	6" * 12'7 1/2"	8'4 3/4"	18 1/2"	14 2/3"	13 3/4"	23°	23°	15°	

Weights Poids



Axle
Essieu
lbs

	1	2	3	4	5	Total weight (metric tons) Poids total t
	26500	26500	26500	26500	26500	132500 ¹⁾

¹⁾ with 15400 lbs counterweight / avec contrepoids 15400 lbs



Load (kips)
Forces de levage kips

330²⁾
236
178
116
50
17.6

No. of sheaves
Poullies

9
7
5
3
1
-

No. of lines
Brins

18
14
11
7
3
1

Weight lbs
Poids lbs

2900
2730
1550
1550
990
550

²⁾ on request / sur demande

Working speeds Vitesses



km/h

km/h 



Drive
Mécanismes



360°



	1	2	3	4	5	R	 %	
	9.3	14.3	22.3	33	47	8	-	
	5	8	13	19.3	27.3	4.7	45 %	
	16.00 R 25							

	infinitely variable en continu	Rope diameter / Rope length Diam. du câble / Longueur du câble	Max. single line pull Effort au brin maxi.
0 - 362 ft/min single line ft/min au brin simple		27/32" / 900'	17400 lbs
0 - 362 ft/min single line ft/min au brin simple		27/32" / 656'	17400 lbs
0 - 1.8 rpm			
	approx. 50 seconds to reach 83° boom angle env. 50 s jusqu'à 83°		
	approx. 400 seconds for boom extension from 41 ft - 184 ft env. 400 s pour passer de 41 ft - 184 ft		

Equipment Equipement

Crane carrier

Frame	Liebherr designed and manufactured, box type, torsion resistant, all-welded construction made of high-tensile structural steel.
Outriggers	4-point support, all-hydraulic horizontal and vertical operation.
Engine	8 cylinder, watercooled Liebherr Diesel, type D 9408 TI-E, 400 kW (544 HP) at 2100 rpm acc. to ECE-R 24.03 and 2001/27/EG (Euro 3), max. torque 1825 lbs-ft at 1575 rpm. Fuel tank capacity: 132 gallons.
Transmission	Allison automatic transmission with torque converter and hydrodynamic retarder brake, 5 forward and 1 reverse speed. Transfer case with off-road range.
Axles	All axles steered. Axles 1, 4 and 5 with planetary gears and differential locks.
Suspension	All axles with hydropneumatic suspension and hydraulic locking facility.
Tyres	10 tyres. Tyre size: 16.00 R 25.
Steering	Hydraulic power steering with dual circuit hydraulic system, mechanical/hydrostatic from lower cab. Stand-by steering pump. Steering acc. to EC directive 70/311/EEC.
Brakes	Service brake: Dual circuit, servo-air brake, acting on all wheels. Hand brake: by spring action on all wheels of axles 2 to 5. Brakes acc. to EC directive 71/320/EEC.
Driver's cab	Spacious all-steel cab on resilient mountings, safety glass windows and full range of instruments.
Electrical system	24 V DC, 2 batteries, lighting according to countries' regulations.

Crane superstructure

Frame	Liebherr-made, torsion-resistant, welded construction made of high-tensile structural steel. Connection to truck chassis by triple roller slewing ring, designed for 360° continuous rotation.
Crane engine	4 cylinder, watercooled Liebherr Diesel, type D 924 T-E, 120 kW (163 HP) at 1800 rpm acc. to EPA/CARB and to directive 97/68 EG, stage 1, max. torque 529 lbs-ft at 1200 rpm. Fuel tank capacity: 79 gallons.
Crane drive	Diesel-hydraulic, with 1 duplex axial-piston pump with automatic output control, 1 duplex gear-type pump, open regulated hydraulic circuits. The hydraulic drive in compact construction is directly flanged to the diesel engine.
Crane control	Load sensing system, 4 working motions can be performed at the same time, by 2 control levers (joy stick type).
Hoist gear	Axial piston fixed displacement motor, hoist drum with integrated planetary gear and spring loaded static brake.
Luffing gear	1 differential hydraulic ram with safety check valve.
Slewing gear	Axial piston fixed displacement motor, planetary gear, spring loaded static brake.
Crane cab	All-steel construction fully galvanized, safety glazing, heater, controls and instruments.
Safety devices	LICCON safe load indicator, hoist limit switch, safety valves against rupture of pipe and hoses.
Telescopic boom	1 base section and 5 telescopic sections, hydraulically extendable under load. All sections extendable independently. Boom length: 41 ft – 184 ft.
Electrical system	24 V DC, 2 batteries.

Complementary equipment

Folding jib	37 ft to 92 ft long, for mounting on telescopic boom at 0°, 20° or 40°.
Telescopic boom extension	23 ft long lattice section, thus 23 ft higher pinning point for swing-away jib.
2nd hoist gear	For two-hook operation, or with folding jib in case main hoist shall remain reeved.
Drive 10 x 8	Axle 2 additionally driven.
Other items of equipment available on request.	